

**FB4A (50/60 Hz)
Direct - Expansion
Fan Coil
18,000 Thru 70,000 Btuh**



Turn to the Experts™

Product Data

Carrier's FB4A Direct Expansion multipoise fan coils are designed to cover a wide range of air handling requirements. They are compact and ready to fit where needed — in the basement, crawlspace, attic, utility room, or closet.



Features/Benefits

- 8 sizes from 1.5 up to 6 ton cooling capacity.
- High static up to 0.7 inch water (175 Pa) for all sizes.
- A-coil design for sizes 48 – 70, and sloped-coil for sizes 18 – 42.
- Efficient lanced sine-wave aluminum fins.
- High-impact thermal plastic condensate pan.
- Primary and secondary drain connection with brass inserts.
- Multipoise design for maximum versatility.
- Field installation heater packages.
- Solid state interlock control board with built-in fuse.
- 1-inch thickness rubber cabinet insulation with 32 kg/m³ density.
- Sweat type connection.
- Multiple electric entries.
- Inspection plate to facilitate cleaning the coil.
- 3-speed motors for all sizes, in field selection.
- Polyester powder painted steel cabinet to withstand harsh Middle Eastern climatic conditions.
- Replaceable 5-amp. Blade-type auto fuse protects against transformer secondary short.
- 40 VA. 208/230 V transformer.
- Permanent filter with aluminum frame 1 inch, flame retardant polyester fibers.
- 208/230 V 1phase 60 Hz and 220 V 1 phase 50 Hz models are available.

FB4A direct expansion fan coil is designed for medium and high static pressure, up to 0.7 inches water (175 Pa) with cooling capacity from 5.3 k watt (18.0 kbtuh) to 21.5 k watt (73.4 kbtuh).

FB4A series is available in eight sizes with an airflow from 236 l/s (500 CFM) to 920 l/s (2000 CFM). FB4A series can be installed vertical or horizontal. Coils are made of efficient lanced sine-wave aluminum fins mechanically bonded to copper tubes for superior heat transfer. 1-inch thick rubber

cabinet insulation with density 32 kg/m³ minimize energy losses and increase unit efficiency. FB4A series comes with polyester powder painted zinc coated galvanized steel casing. Super quiet multi 3 speed motor for field selection & electric heaters are available option at field installation.

Table of Contents

	Page
Model Numbers and Nomenclature.....	2
Physical Data.....	3
Performance Data.....	4
Base Unit Dimensions.....	6
Fan Performance & Sound power.....	7
Application Data.....	8
Typical Wiring Schematic.....	9
Guide Specification.....	10

FB4A

Model Number Nomenclature

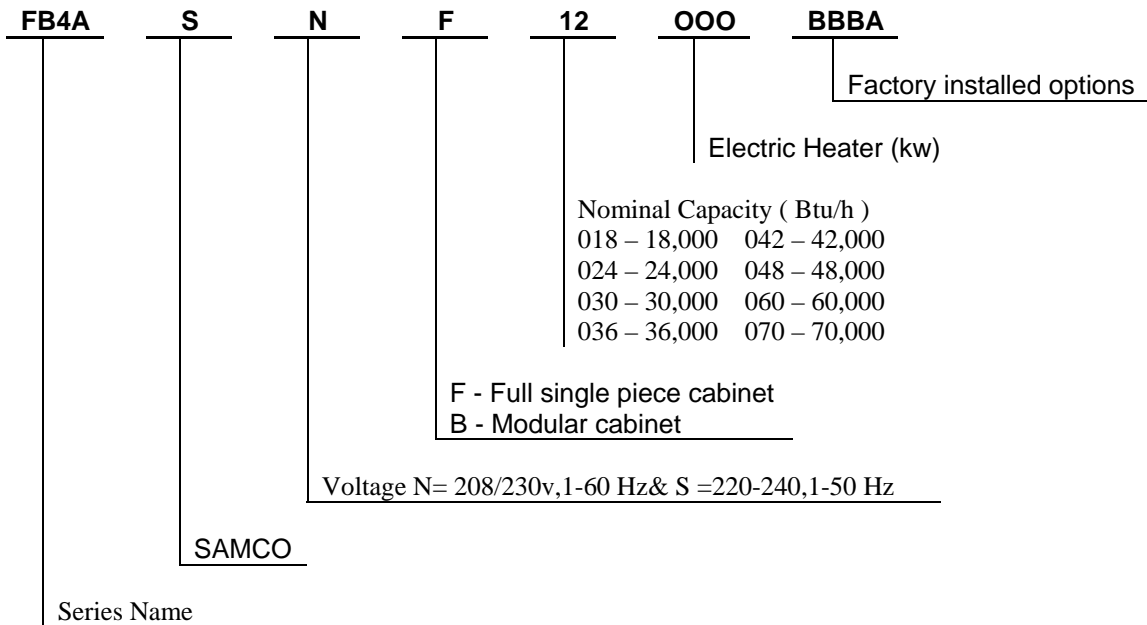

Quality Assurance

SAMCO



Approvals :
 ISO 9001 : 2000
 EN ISO 9001 : 2000
 ANSI/ASQC Q9001 : 2000

0410019950420

Physical Data

MODEL FB4A *	018	024	030	036	042	048	060	—	070
SHIPPING WT (Lb) FB4A	96	112	120	127	146	157	175	—	201
REFRIGERANT METERING DEVICE	Bypass AccuRater								
PISTON SIZE	55	63	70	76	84	88	96	—	101
Rows and Fins Per In.	2 and 14.5	3 and 14.5	3 and 14.5	3 and 14.5	3 and 14.5	3 and 14.5	3 and 14.5	3 and 14.5	3 and 14.5
Face Area (Sq Ft)	2.23	2.23	2.97	2.97	3.46	4.45	5.93	7.42	7.42
Configuration	Slope	Slope	Slope	Slope	Slope	A	A	A	A
Air Discharge CFM (Nominal) Motor Hp (PSC)	650 1/5	850 1/4	1100 1/3	1300 1/3	1500 1/2	1700 3/4	2000 3/4	1700 1/2	2000 3/4
FILTER	21-1/2 x 13		21-1/2 x 16-3/8		21-1/2 x 19-7/8			21-1/2 x 23-5/16	

FAN COIL ELECTRICAL DATA (UNITS WITHOUT ELECTRICAL HEAT)

UNIT SIZE	VOLTS (1 PHASE)	FLA‡	MIN CKT AMPS	BRANCH CIRCUIT	
				Min Wire Size Awg*	Fuse Amps
018	208/230	1.5	1.9	14	15
024	208/230	1.8	2.3	14	15
030	208/230	2.4	3.0	14	15
036	208/230	2.7	3.4	14	15
042	208/230	2.9	3.7	14	15
048	208/230	4.3	5.4	14	15
060, 070	208/230	5.4	6.8	14	15
070	208/230	5.2	6.5	14	15

* Use copper wire only. Use 75°C only in this application. When using non-metallic (NM) sheathed cable, wire size required should be based on that

of 60°C conductors, instead of wire sizes shown in table above per NEC Article 336-26.

‡ Based on FB4B.

FLA — Full Load Amps

NOTE: If branch circuit wire length exceeds 100 ft, consult NEC 215-2 to determine maximum wire length. Use 2% voltage drop.

Performance Data - (50/60 HZ)

Nom Cap. MBtuh	Evaporator Air		CONDENSER AIR ENTERING Deg. F																	
			75			85			95			105			115			120		
	CFM, BP	EWB	Cap. MBtuh		Tot Sys Kw	Cap. MBtuh		Tot Sys Kw	Cap. MBtuh		Tot Sys Kw	Cap. MBtuh		Tot Sys Kw	Cap. MBtuh		Tot Sys Kw	Cap. MBtuh		Tot Sys Kw
			Tot	Sen	Tot	Sen	Tot	Sen	Tot	Sen	Tot	Sen	Tot	Sen	Tot	Sen	Tot	Sen		
18	525	72	23.6	11.2	2.19	22.8	11.0	2.35	21.7	10.6	2.51	21.3	10.6	2.73	20.5	10.5	2.92	19.4	10.1	3.03
		67	21.9	13.9	2.13	20.8	13.6	2.29	19.6	13.1	2.44	19.0	13.1	2.64	18.1	13.0	2.78	17.0	12.6	2.86
		62	19.8	16.4	2.07	18.6	15.9	2.21	17.4	15.3	2.33	16.9	15.3	2.50	16.2	14.8	2.65	15.4	14.2	2.73
		57	18.8	17.3	2.05	18.0	16.5	2.18	17.0	15.6	2.31	16.8	15.4	2.50	16.2	14.8	2.65	15.4	14.2	2.74
	600	72	23.9	11.6	2.24	23.1	11.4	2.40	22.1	11.1	2.99	21.7	11.2	2.80	20.8	11.0	2.97	19.7	10.7	3.08
		67	22.3	14.7	2.19	21.2	14.4	2.34	20.0	14.0	2.50	19.4	14.0	2.71	18.4	13.9	2.84	17.3	13.5	2.92
		62	20.3	17.5	2.13	19.1	17.0	2.27	17.9	16.4	2.40	17.5	16.1	2.59	16.9	15.5	2.73	16.1	14.8	2.82
		57	19.7	18.1	2.11	18.8	17.2	2.26	17.8	16.4	2.40	17.5	16.1	2.59	16.9	15.5	2.73	16.1	14.8	2.82
	675	72	24.2	11.9	2.29	23.3	11.8	2.45	22.3	11.5	2.62	22.0	11.7	2.85	21.1	11.6	3.03	20.0	11.2	3.14
		67	22.6	15.4	2.24	21.5	15.2	2.39	20.3	14.8	2.55	19.7	14.9	2.76	18.7	14.7	2.91	17.6	14.3	3.00
		62	20.7	18.5	2.18	19.6	18.0	2.33	18.5	17.0	2.49	18.1	16.7	2.67	17.5	16.1	2.83	16.7	15.3	2.92
		57	20.4	18.7	2.17	19.5	17.9	2.33	18.5	17.0	2.49	18.1	16.6	2.67	17.5	16.1	2.83	16.7	15.3	2.92
24	550	72	28.7	13.3	2.67	27.7	13.0	2.87	26.4	12.6	3.07	25.9	12.6	3.34	24.9	12.4	3.56	23.6	12.0	3.69
		67	26.6	16.5	2.60	25.3	16.1	2.79	23.8	15.6	2.98	23.1	15.6	3.22	22.0	15.4	3.39	20.7	14.9	3.48
		62	24.0	19.5	2.53	22.6	18.8	2.69	21.2	18.2	2.85	20.6	18.2	3.06	19.6	17.6	3.23	18.7	16.8	3.33
		57	22.8	20.5	2.50	21.8	19.5	2.66	20.7	18.6	2.81	20.4	18.3	3.05	19.6	17.6	3.23	18.7	16.8	3.34
	625	72	29.1	13.8	2.73	28.1	13.5	2.93	26.8	13.2	3.13	26.4	13.3	3.41	25.3	13.1	3.63	24.0	12.7	3.75
		67	27.1	17.4	2.67	25.8	17.1	2.86	24.3	16.6	3.05	23.6	16.7	3.31	22.4	16.5	3.47	21.1	16.0	3.56
		62	24.6	20.8	2.60	23.2	20.1	2.77	21.8	19.5	2.93	21.3	19.1	3.15	20.5	18.4	3.34	19.6	17.6	3.45
		57	23.9	21.4	2.57	22.8	20.4	2.76	21.7	19.4	2.93	21.3	19.0	3.15	20.5	18.4	3.34	19.6	17.6	3.45
	700	72	29.4	14.1	2.80	28.3	14.0	2.99	27.1	13.7	3.20	26.7	13.8	3.48	25.6	13.7	3.70	24.3	13.3	3.83
		67	27.4	18.3	2.73	26.2	18.0	2.91	24.7	17.6	3.11	23.9	17.7	3.37	22.7	17.5	3.55	21.4	17.0	3.66
		62	25.1	21.9	2.66	23.8	21.3	2.84	22.5	20.1	3.03	22.0	19.7	3.26	21.3	19.1	3.45	20.3	18.2	3.57
		57	24.8	22.2	2.64	23.7	21.2	2.84	22.5	20.1	3.03	22.0	19.7	3.26	21.3	19.1	3.45	20.3	18.2	3.57
30	1000	72	35.6	18.4	2.89	34.3	18.0	3.11	32.7	17.5	3.32	31.1	17.0	3.72	29.9	16.7	3.97	28.3	16.1	4.12
		67	32.9	22.9	2.82	31.3	22.3	3.02	29.4	21.6	3.22	27.7	20.9	3.59	26.4	20.7	3.77	24.9	20.0	3.88
		62	29.8	27.0	2.74	28.0	26.1	2.91	26.3	25.2	3.08	24.7	24.4	3.40	23.6	23.6	3.60	22.5	22.6	3.71
		57	28.3	28.4	2.70	27.0	27.1	2.88	25.7	25.7	3.05	24.5	24.5	3.40	23.6	23.6	3.60	22.5	22.6	3.72
	1150	72	36.0	19.1	2.96	34.8	18.7	3.17	33.2	18.2	3.39	31.7	17.8	3.80	30.4	17.6	4.04	28.8	17.0	4.18
		67	33.5	24.1	2.89	31.9	23.6	3.09	30.1	23.0	3.30	28.3	22.4	3.69	26.9	22.1	3.87	25.3	21.5	3.97
		62	30.5	28.8	2.81	28.8	27.9	3.00	27.0	27.0	3.17	25.6	25.6	3.52	24.7	24.7	3.72	23.5	23.5	3.84
		57	29.6	29.7	2.78	28.3	28.3	2.98	26.9	26.9	3.17	25.5	25.6	3.52	24.7	24.7	3.72	23.5	23.5	3.84
	1300	72	36.4	19.6	3.03	35.1	19.3	3.24	33.6	18.9	3.46	32.1	18.6	3.87	30.8	18.4	4.12	29.2	17.9	4.27
		67	33.9	25.3	2.96	32.4	24.9	3.15	30.6	24.3	3.37	28.7	23.8	3.75	27.3	23.5	3.96	25.7	22.8	4.08
		62	31.1	30.3	2.88	29.5	29.5	3.07	27.8	27.9	3.28	26.5	26.5	3.64	25.6	25.6	3.85	24.4	24.4	3.97
		57	30.7	30.7	2.86	29.4	29.4	3.07	27.8	27.9	3.28	26.5	26.5	3.64	25.6	25.6	3.85	24.4	24.4	3.97
36	1050	72	40.8	20.8	3.50	39.3	20.4	3.77	37.4	19.7	4.02	35.7	19.2	4.24	34.3	18.9	4.53	32.5	18.2	4.70
		67	37.7	25.9	3.41	35.9	25.2	3.66	33.7	24.4	3.90	31.8	23.6	4.10	30.3	23.4	4.31	28.5	22.6	4.43
		62	34.1	30.5	3.32	32.1	29.5	3.53	30.1	28.5	3.73	28.3	27.6	3.89	27.0	26.7	4.11	25.8	25.5	4.24
		57	32.4	32.1	3.28	31.0	30.6	3.49	29.4	29.1	3.69	28.1	27.7	3.88	27.1	26.7	4.11	25.8	25.5	4.25
	1200	72	41.3	21.5	3.59	39.9	21.2	3.84	38.1	20.6	4.11	36.3	20.1	4.34	34.8	19.9	4.61	33.0	19.2	4.78
		67	38.4	27.3	3.50	36.6	26.7	3.74	34.5	26.0	4.00	32.4	25.3	4.21	30.8	25.0	4.41	29.0	24.3	4.53
		62	34.9	32.5	3.40	33.0	31.5	3.64	30.9	30.5	3.84	29.3	28.9	4.01	28.3	28.0	4.24	27.0	26.7	4.38
		57	34.0	33.6	3.37	32.4	32.0	3.62	30.8	30.4	3.84	29.3	28.9	4.01	28.3	27.9	4.24	27.0	26.7	4.38
	1350	72	41.7	22.1	3.67	40.2	21.9	3.93	38.5	21.4	4.19	36.8	21.0	4.42	35.3	20.8	4.71	33.4	20.2	4.88
		67	38.9	28.6	3.59	37.1	28.1	3.82	35.1	27.5	4.09	32.9	26.9	4.29	31.2	26.6	4.52	29.4	25.8	4.66
		62	35.6	34.3	3.49	33.8	33.4	3.72	31.9	31.5	3.98	30.4	30.0	4.15	29.3	29.0	4.39	28.0	27.6	4.54
		57	35.2	34.7	3.47	33.6	33.2	3.72	31.9	31.5	3.98	30.3	30.0	4.15	29.3	29.0	4.39	28.0	27.6	4.54

FB4A

Performance Data - (50/60 HZ)

Nom Cap. MBtuh	Evaporator Air		CONDENSER AIR ENTERING Deg. F																	
			75			85			95			105			115			120		
			CFM, BP	EWB	Cap. MBtuh		Tot Sys Kw	Cap. MBtuh		Tot Sys Kw	Cap. MBtuh		Tot Sys Kw	Cap. MBtuh		Tot Sys Kw	Cap. MBtuh		Tot Sys Kw	Cap. MBtuh
Tot	Sen	Tot			Sen	Tot	Sen	Tot	Sen	Tot	Sen	Tot	Sen	Tot	Sen	Tot	Sen	Tot	Sen	
48	1300	72	54.4	26.5	4.0	52.4	25.9	4.3	49.9	25.1	4.6	46.1	23.6	5.0	44.3	23.3	5.4	41.9	22.4	5.6
		67	50.3	32.9	3.9	47.8	32.1	4.2	45.0	31.0	4.5	41.1	29.2	4.9	39.1	28.8	5.1	36.8	27.9	5.3
		62	45.5	38.8	3.8	42.8	37.6	4.1	40.1	36.3	4.3	36.6	34.0	4.6	34.9	33.0	4.9	33.3	31.5	5.0
		57	43.3	40.8	3.8	41.3	39.0	4.0	39.2	37.0	4.2	36.3	34.2	4.6	35.0	33.0	4.9	33.4	31.5	5.0
	1500	72	55.1	27.4	4.1	53.2	26.9	4.4	50.7	26.2	4.7	46.9	24.9	5.1	45.0	24.5	5.5	42.7	23.7	5.7
		67	51.2	34.7	4.0	48.8	34.0	4.3	46.0	33.1	4.6	41.9	31.2	5.0	39.8	30.9	5.2	37.5	30.0	5.4
		62	46.6	41.4	3.9	44.0	40.1	4.2	41.2	38.9	4.4	37.9	35.7	4.8	36.6	34.5	5.0	34.9	32.9	5.2
		57	45.3	42.7	3.9	43.2	40.7	4.2	41.0	38.7	4.4	37.8	35.7	4.8	36.5	34.5	5.0	34.9	32.9	5.2
	1700	72	55.6	28.2	4.2	53.7	27.8	4.5	51.3	27.2	4.8	47.5	26.0	5.2	45.6	25.7	5.6	43.2	25.0	5.8
		67	51.9	36.4	4.1	49.5	35.8	4.4	46.8	35.0	4.7	42.5	33.1	5.1	40.4	32.8	5.4	38.0	31.8	5.5
		62	47.5	43.7	4.0	45.0	42.5	4.3	42.5	40.1	4.6	39.2	37.0	4.9	37.9	35.8	5.2	36.1	34.1	5.4
		57	46.9	44.2	4.0	44.9	42.3	4.3	42.5	40.1	4.6	39.2	37.0	4.9	37.9	35.8	5.2	36.1	34.1	5.4
60	1450	72	69.7	34.1	5.2	67.3	33.3	5.6	64.0	32.3	5.9	58.5	30.0	6.5	56.2	29.6	6.9	53.2	28.5	7.1
		67	64.5	42.3	5.0	61.4	41.2	5.4	57.7	39.8	5.8	52.1	37.1	6.2	49.6	36.6	6.5	46.7	35.5	6.7
		62	58.3	49.8	4.9	54.9	48.2	5.2	51.5	46.6	5.5	46.4	43.2	5.9	44.3	41.9	6.2	42.3	40.0	6.4
		57	55.5	52.4	4.8	53.0	50.0	5.1	50.3	47.5	5.4	46.0	43.5	5.9	44.4	41.9	6.2	42.3	40.0	6.5
	1650	72	70.6	35.2	5.3	68.2	34.6	5.7	65.1	33.7	6.1	59.5	31.6	6.6	57.1	31.2	7.0	54.2	30.2	7.3
		67	65.7	44.6	5.2	62.6	43.7	5.5	59.0	42.5	5.9	53.2	39.7	6.4	50.5	39.2	6.7	47.6	38.1	6.9
		62	59.8	53.2	5.0	56.4	51.6	5.4	52.8	49.9	5.7	48.0	45.4	6.1	46.4	43.8	6.5	44.3	41.8	6.7
		57	58.1	54.9	5.0	55.4	52.3	5.3	52.6	49.7	5.7	48.0	45.3	6.1	46.4	43.8	6.5	44.2	41.8	6.7
	1850	72	71.3	36.2	5.4	68.8	35.7	5.8	65.8	35.0	6.2	60.3	33.0	6.7	57.8	32.6	7.2	54.8	31.7	7.4
		67	66.5	46.7	5.3	63.5	46.0	5.6	60.0	45.0	6.0	54.0	42.1	6.5	51.2	41.6	6.9	48.3	40.5	7.1
		62	60.9	56.1	5.1	57.7	54.5	5.5	54.5	51.5	5.9	49.8	47.0	6.3	48.1	45.4	6.7	45.8	43.3	6.9
		57	60.1	56.8	5.1	57.5	54.3	5.5	54.5	51.5	5.9	49.8	47.0	6.3	48.1	45.4	6.7	45.8	43.3	6.9
70	1600	72	79.2	37.7	6.5	76.4	36.8	7.0	72.7	35.7	7.4	71.4	35.7	8.1	68.6	35.2	8.6	65.0	33.9	9.0
		67	73.3	46.7	6.3	69.7	45.5	6.8	65.5	44.0	7.2	63.6	44.1	7.8	60.6	43.5	8.2	57.1	42.2	8.5
		62	66.2	55.1	6.1	62.3	53.3	6.5	58.5	51.5	6.9	56.7	51.4	7.4	54.1	49.8	7.8	51.7	47.5	8.1
		57	63.0	57.9	6.1	60.2	55.3	6.5	57.1	52.5	6.8	56.2	51.7	7.4	54.2	49.8	7.8	51.7	47.5	8.1
	1800	72	80.2	38.9	6.6	77.4	38.2	7.1	73.9	37.2	7.6	72.7	37.5	8.3	69.8	37.0	8.8	66.1	35.9	9.1
		67	74.6	49.3	6.5	71.1	48.3	6.9	67.0	47.0	7.4	64.9	47.2	8.0	61.7	46.6	8.4	58.1	45.3	8.6
		62	67.9	58.8	6.3	64.0	57.0	6.7	60.0	55.2	7.1	58.7	53.9	7.7	56.7	52.1	8.1	54.0	49.7	8.4
		57	66.0	60.7	6.2	62.9	57.8	6.7	59.8	55.0	7.1	58.6	53.9	7.7	56.6	52.1	8.1	54.0	49.7	8.4
	2000	72	80.9	40.0	6.8	78.2	39.5	7.3	74.7	38.7	7.8	73.6	39.2	8.4	70.6	38.8	9.0	66.9	37.7	9.3
		67	75.5	51.7	6.6	72.1	50.9	7.1	68.1	49.8	7.6	65.9	50.1	8.2	62.5	49.5	8.6	58.9	48.1	8.9
		62	69.2	62.0	6.5	65.6	60.3	6.9	61.9	57.0	7.4	60.8	55.9	7.9	58.8	54.0	8.4	56.0	51.5	8.7
		57	68.3	62.8	6.4	65.3	60.1	6.9	61.9	57.0	7.4	60.8	55.9	7.9	58.8	54.0	8.4	56.0	51.5	8.7

Multipliers to Determine the Performance With Other Indoor Coils

Condenser N. Cap. MBtuh	Evaporator N. Cap. MBtuh	Cooling Cap.	Power
18	24	1.10	1.07
24	30	1.05	1.05
30	36	1.03	1.05
36	42	1.04	1.05
48	60	1.05	1.05
60	70	1.02	1.03

Notes:

- Net Capacities shown include a deduction for evaporator fan motor heat.
- Formulas:
Leaving db= Entering - Sensible Heat Cap./(1.09 x CFM)
Leaving wb= wb corresponding to air leaving coil (hwb)
h wb leaving = hwb entering - Total Cap(Btuh)/(4.5 X CFM)
- Direct Interpolation Permissible. Do not extrapolate.

Performance Data

Fan Performance – (60 HZ) – ENGLISH

SIZE	BLOWER MOTOR SPEED	TOTAL EXTERNAL STATIC PRESSURE (IN. WC)											
		0.10		0.20		0.30		0.40		0.50		0.60	
		208V	230V	208V	230V	208V	230V	208V	230V	208V	230V	208V	230V
018	HIGH	860	925	815	870	765	820	715	760	645	690	550	600
	MED	650	740	625	705	585	660	545	620	480	555	385	450
	LOW	565	650	535	620	500	590	460	545	405	480	330	385
024	HIGH	945	975	900	930	840	870	780	805	695	725	560	595
	MED	835	900	795	855	745	800	690	740	610	650	470	510
	LOW	605	695	575	665	530	625	485	580	425	510	340	395
030	HIGH	1260	1305	1200	1245	1135	1170	1065	1110	985	1015	880	900
	MED	1055	1170	1020	1115	980	1055	930	1000	960	920	755	810
	LOW	830	950	805	925	780	890	740	850	685	790	595	700
036	HIGH	1485	1550	1425	1490	1365	1420	1300	1350	1230	1275	1150	1190
	MED	1235	1380	1200	1325	1160	1265	1110	1210	1055	1140	985	1070
	LOW	1035	1185	1010	1150	980	1115	940	1070	890	1010	825	935
042	HIGH	1580	1710	1540	1655	1495	1595	1440	1530	1375	1445	1290	1355
	MED	1400	1570	1375	1525	1350	1480	1305	1425	1255	1360	1175	1280
	LOW	1195	1375	1180	1350	1165	1325	1135	1285	1085	1240	1020	1160
048	HIGH	1880	1935	1785	1830	1700	1735	1615	1645	1520	1555	1430	1460
	MED	1740	1840	1660	1750	1585	1660	1510	1575	1435	1485	1350	1390
	LOW	1425	1605	1395	1555	1360	1495	1315	1430	1255	1360	1170	1270
060	HIGH	2145	2245	2085	2185	2030	2115	1965	2045	1905	1975	1830	1895
	MED	2025	2175	1970	2110	1915	2050	1860	1980	1805	1905	1740	1830
	LOW	1680	1895	1655	1855	1625	1810	1595	1765	1555	1705	1500	1645
070	HIGH	2205	2285	2130	2205	2050	2120	1960	2025	1875	1930	1790	1825
	MED	1880	2075	1845	2015	1795	1945	1745	1870	1675	1790	1595	1700
	LOW	1570	1825	1560	1795	1545	1745	1520	1700	1480	1640	1420	1565

Fan Performance – (50 HZ) – ENGLISH

UNIT SIZE	BLOWER MOTOR SPEED	EXTERNAL STATIC PRESSURE—In. wc				
		0.10	0.20	0.30	0.40	0.50
018	HIGH	825	770	672	562	—
	MED	736	678	573	—	—
	LOW	631	579	—	—	—
024	HIGH	791	731	643	504	—
	MED	720	677	570	—	—
	LOW	564	523	—	—	—
030	HIGH	1100	1022	914	782	634
	MED	980	910	815	680	—
	LOW	880	818	720	—	—
036	HIGH	1290	1210	1125	1030	928
	MED	1122	1058	992	916	835
	LOW	970	925	878	808	—
042	HIGH	1466	1394	1312	1210	1012
	MED	1296	1232	1152	1050	—
	LOW	1082	1046	1000	930	—
048	HIGH	1720	1622	1518	1400	1260
	MED	1632	1535	1436	1330	1212
	LOW	1510	1422	1334	1226	—
060	HIGH	1876	1788	1696	1600	1496
	MED	1702	1625	1548	1462	—
	LOW	1422	1372	1322	—	—
070	HIGH	2200	2110	2020	1920	1805
	MED	1985	1925	1855	1775	1680
	LOW	1655	1625	1585	1535	—

NOTES:

- Airflow based upon dry coil at 230v with factory approved filter and electric heater (2 element heater, sizes 018 through 036; 3 element heater, sizes 042 through 060).
- To avoid potential for condensate blowing out of drain pan prior to making drain trap:
 - Return static pressure must be less than 0.4 in. wc
 - Horizontal applications of 048-070 sizes must have supply static greater than 0.20 in.wc

FB4A

Performance Data - Cont.

MINIMUM CFM AND MOTOR SPEED SELECTION

SIZES	HEATER KW									
	3	5	8	9	10	15	18	20	24	30
018	525	525	525	—	600*	—	—	—	—	—
024	700	700	700	—	700	775*	—	—	—	—
030	—	875	875	—	875	875	—	1060*	—	—
036	—	1050	970	970	970	920	—	1040	—	—
042	—	—	1225	1225	1225	1225	1225	1225	—	—
048, 054	—	—	1400	1400	1400	1400	1400	1400	1400	1400
060, 070	—	—	1750	1750	1750	1750	1750	1750	1750	1750

FACTORY-INSTALLED FILTER STATIC PRESSURE DROP (IN. WC)

UNIT SIZE	CFM								
	400	600	800	1000	1200	1400	1600	1800	2000
018	0.02	0.044	0.075	—	—	—	—	—	—
024	—	0.044	0.075	0.110	—	—	—	—	—
030	—	—	0.048	0.072	0.100	—	—	—	—
036	—	—	—	0.072	0.100	0.130	—	—	—
042	—	—	—	—	0.070	0.092	0.120	—	—
048	—	—	—	—	—	0.092	0.120	0.152	—
060	—	—	—	—	—	—	0.120	0.152	0.187
070	—	—	—	—	—	—	0.086	0.105	0.130

ELECTRIC HEATER STATIC PRESSURE DROP (IN. WC)

018-036			042-70		
HEATER ELEMENTS	KW	EXTERNAL STATIC PRESSURE CORRECTION	HEATER ELEMENTS	KW	EXTERNAL STATIC PRESSURE CORRECTION
0	0	+0.02	0	0	+0.04
1	3, 5	+0.01	2	8, 10	+0.02
2	8, 10	0	3	9, 15	0
3	9, 15	-0.02	4	20	-0.02
4	20	-0.04	6	18, 24, 30	-0.10

Accessory electric heaters

HEATER PART NO.	KW @ 240V	VOLTS/PH	STAGES (KW OPERATING)	INTERNAL CIRCUIT PROTECTION	FAN COIL SIZE USED WITH	HEATING CAP.** @ 230V
KFCEH0401N03	3	230/1	3	None	018-024	9,400
KFCEH0501N05	5	230/1	5	None	018-060	15,700
KFCEH0801N08	8	230/1	8	None	018-070	25,100
KFCEH0901N10	10	230/1	10	None	018-070	31,400
KFCEH3201F20	20	230/1	5, 20	Fuse‡	030-070	62,800
KFCEH1601315	15	230/3	5, 15	None	036-070	47,100
KFCEH2001318	18	230/3	6, 12, 18	None	042-070	56,500
KFCEH3401F24	24	230/3*	8, 16, 24	Fuse	048, 060, 070	78,300
KFCEH3501F30	30	230/3*	10, 20, 30	Fuse	048, 060, 070	94,100
KFCEH2401C05	5	230/1	5	Circuit Breaker	018-060	15,700
KFCEH2501C08	8	230/1	8	Circuit Breaker	018-070	25,100
KFCEH2601C10	10	230/1	10	Circuit Breaker	018-070	31,400
KFCEH3301C20	20	230/1	5, 20	Circuit Breaker	030-070	62,800
KFCEH2901N09	9	230/1†	3, 9	None	036-070	28,200
KFCEH3001F15	15	230/1	5, 15	Fuse‡	024-070	47,100
KFCEH3101C15	15	230/1	5, 15	Circuit Breaker	024-070	47,100

* Field convertible to 1 phase.

† Field convertible to 3 phase.

‡ Single point wiring kit required for these heaters in Canada.

** Blower motor heat not included.

Carrier accessories

ITEM	ACCESSORY PART NO.*	FAN COIL SIZE USED WITH
Disconnect Kit	KFADK0101DSC	Cooling controls and heaters 3- through 10-kw
Downflow Base Kit	KFACB0101CFB	018, 024
KFACB0201CFB	030, 036	
KFACB0301CFB	038, 042, 048, 060	
KFACB0401CFB	054, 070	
Downflow Conversion Kit	KFADC0201SLP	Slope Coil Units—018, 024, 030, 036, 042
KFADC0401ACL	A-Coil Units—038, 048, 054, 060, 070	
Single-Point Wiring Kit	KFASP0101SPK	Only with 15- and 20-kw Fused Heaters
Filter Kit (12 Pack)	KFAFK0112SML	018, 024
KFAFK0212MED	030, 036	
KFAFK0312LRG	038, 042, 048, 060	
KFAFK0412XXL	054, 070	
Power Plug Kit (25 Pack)	KFAPP0125PLG	FA4A 018-060
PVC Condensate Trap Kit (50 pack)	KFAET0150ETK	All Sizes
Air Cleaner 240-volt Conversion Kit	KEAVC0201240	All Sizes
Downflow/Horizontal Conversion Gasket Kit	KFAHD0101SLP	All

* Factory-authorized and listed, field installed.

Smart heat

HEATER PART NO.	KW @ 240V	VOLTS/PH	STAGES (KW OPERATING)	INTERNAL CIRCUIT PROTECTION	FAN COIL SIZE USED WITH	HEATING CAP.* @ 230V
KFCEH0101H10	9	230/1	3, 6, 9	None	018-036	28,200
KFCEH0201H15	15	230/1	3, 8, 11, 15	Fuse	024-048	47,100
KFCEH0301H20	20	230/1	5, 10, 15, 20	Fuse	030-070	62,800

* Blower motor heat not included.

When using units with 20-, 24-, and 30-kw electric heaters, maintain a 1-in. clearance from combustible materials to discharge plenum and ductwork and maintain a distance of 36 in. from the unit. Use an accessory downflow base to maintain proper clearance on downflow installations.

Use flexible connectors between ductwork and unit to prevent transmission of vibration. When electric heater is installed, use heat resistant material for flexible connector between ductwork and unit at discharge connection. Ductwork passing through unconditioned space must be insulated and covered with vapor barrier.

ESTIMATED SOUND POWER LEVEL 60Hz (dBA)

UNIT SIZE	CONDITIONS		OCTAVE BAND CENTER FREQUENCY*						
	CFM	Ext Static Pressure	63	125	250	500	1000	2000	4000
018	600	0.25	64.7	60.7	56.7	53.7	51.7	49.7	45.7
024	800	0.25	66.0	62.0	58.0	55.0	53.0	51.0	47.0
030	1000	0.25	67.0	63.0	59.0	56.0	54.0	52.0	48.0
036	1200	0.25	67.8	63.8	59.8	56.8	54.8	52.8	48.8
042	1400	0.25	68.4	64.4	60.4	57.4	55.4	53.4	49.4
048	1600	0.25	69.0	65.0	61.0	58.0	56.0	54.0	50.0
060	2000	0.25	70.0	66.0	62.0	59.0	57.0	55.0	51.0
070	2000	0.25	70.0	66.0	62.0	59.0	57.0	55.0	51.0

* Estimated sound power levels have been derived using the method described in the 1987 ASHRAE HVAC Systems & Applications Handbook, Chapter 52, p. 52.7.

ESTIMATED SOUND POWER LEVEL 50Hz (dBA)

UNIT SIZE	Lw (dB)										
	English		SI		Octave Band Center Frequency (Hz)						
	CFM	ESP	L/S	ESP	63	125	250	500	1000	2000	4000
FB4-018 50 Hz	600	0.29	283	72	66.0	62.0	58.0	55.0	53.0	51.0	47.0
FB4-024 50 Hz	750	0.17	354	42	62.4	58.4	54.4	51.4	49.4	47.4	43.4
FB4-030 50 Hz	1000	0.23	472	57	66.2	62.2	58.2	55.2	53.2	51.2	47.2
FB4-036 50 Hz	1200	0.44	566	110	72.7	68.7	64.7	61.7	59.7	57.7	53.7
FB4-042 50 Hz	1250	0.37	590	92	71.3	67.3	63.3	60.3	58.3	56.3	52.3
FB4-048 50 Hz	1600	0.22	755	55	67.9	63.9	59.9	56.9	54.9	52.9	48.9
FB4-060 50 Hz	1800	0.36	755	90	72.7	68.7	64.7	61.7	59.7	57.7	53.7
FB4-070 50 Hz	2000	0.37	944	92	73.4	69.4	65.4	62.4	60.4	58.4	54.4

METHOD: Estimated Fan Sound Power (in decibels 10E-12 watts) is calculated in accordance with procedure described in ASHRAE 1987 HVAC "Systems and Applications Handbook," Chapter 52, "Sound and Vibration Control," using the "Specific Sound Power Level" approach.

ACCURACY: This is a prediction method, based on an accepted method which has demonstrated satisfactory results in field applications. However, field test results may generate sound pressure values which differ from these predicted values, as the current state of the art in determining sound power varies in accuracy from 0.2 db in mid-range (250 to 4000 Hz bands) to 3 to 4 db in 125 and 8000 Hz bands and up to 6 to 8 db in 63 Hz band.

MINOR CHANGES: Use for estimating sound power at other conditions of airflow and external static pressure.

Conversion factors

METRIC TECH	X =	ENGLISH UNIT	X =	SI UNIT
Area				
cm			100	mm
cm	0.1550	in.	645.2	mm
m			1.0	m
m	10.76	ft	0.09290	m
Length				
µm			1.0	µm
µm	39.37	micro-in.	0.0254	µm
mm			1.0	mm
mm	0.03937	in.	25.4	mm
mm	0.003281	ft	304.8	mm
m			1.0	m
m	3.281	ft	0.3048	m
m	1.094	yd	0.9144	m
Mass				
g			1.0	g
g	0.03527	oz	28.35	g
kg			1.0	kg
kg	2.205	lb	0.4536	kg
tonne. Mg			1.0	tonne. Mg
tonne. Mg	1.102	U.S. ton (2000 lb)	0.9072	tonne. Mg
Power				
kcal/h			1.163	W
kcal/h	3.968	Btu/h	0.2931	W
HP metric			0.7355	kW
HP metric	0.9863	HP (550 $\frac{ft \cdot lb}{s}$)	0.7457	kW
Mcal/h			1.163	kW
Mcal/h	0.3307	Ton ref.	3.517	kW
Pressure				
mm w.g 4°C			9.806	Pa
mm w.g 4°C	0.03937	in H ₂ O 39.2°F	249.1	Pa
mm Hg 0°C			0.1333	kPa
mm Hg 0°C	0.03937	in Hg 32°F	3.386	kPa
kg/cm ²			98.07	kPa
kg/cm ²	14.22	psi	6.895	kPa
mH ₂ O	3.281	ft H ₂ O	2.989	kPa

METRIC TECH	X =	ENGLISH UNIT	X =	SI UNIT
Temperature				
Interval				
°C			1.0	k
°C	1.8	°F	0.5556	°C
Velocity				
m/s			1.0	m/s
m/s	3.281	ft/s	0.3048	m/s
m/s	196.9	ft/min	0.00508	m/s
Volume				
mm			1.0 x 10 ⁻⁶	L
mm	6.102x10 ³	in.	0.01639	L
L			1.0	L
L	0.03531	ft	28.32	L
m			1.0	m
m	1.308	yd	0.7646	m
L	0.2642	U.S. gal	3.785	L
L	2.113	U.S. pint	0.4732	L
mL .cm			1.0	mL
mL .cm	0.03381	U.S. oz	29.57	mL
Volume/Time				
m ³ /h			0.2778	L/s
m ³ /h	0.5886	ft ³ /min	0.4719	L/s
m ³ /h	4.403	U.S. gal/min	0.06309	L/s
L/h			2.778x10 ⁻⁴	L/s
L/h	4.303x10 ³	U.S. gal/min	0.06309	L/s
(m ³ /h)/ (1000 kcal/h)	1.780	cfm/ton	0.1342	L/s • kW
METRIC TECH	CONVERSION FACTOR	ENGLISH UNIT	CONVERSION FACTOR	SI UNIT
Temperature				
°C			°C + 273.15	K
°C	(°C x 1.8) + 32	°F	(°F - 32) ÷ 1.8	°C

Typical Wiring Schematic

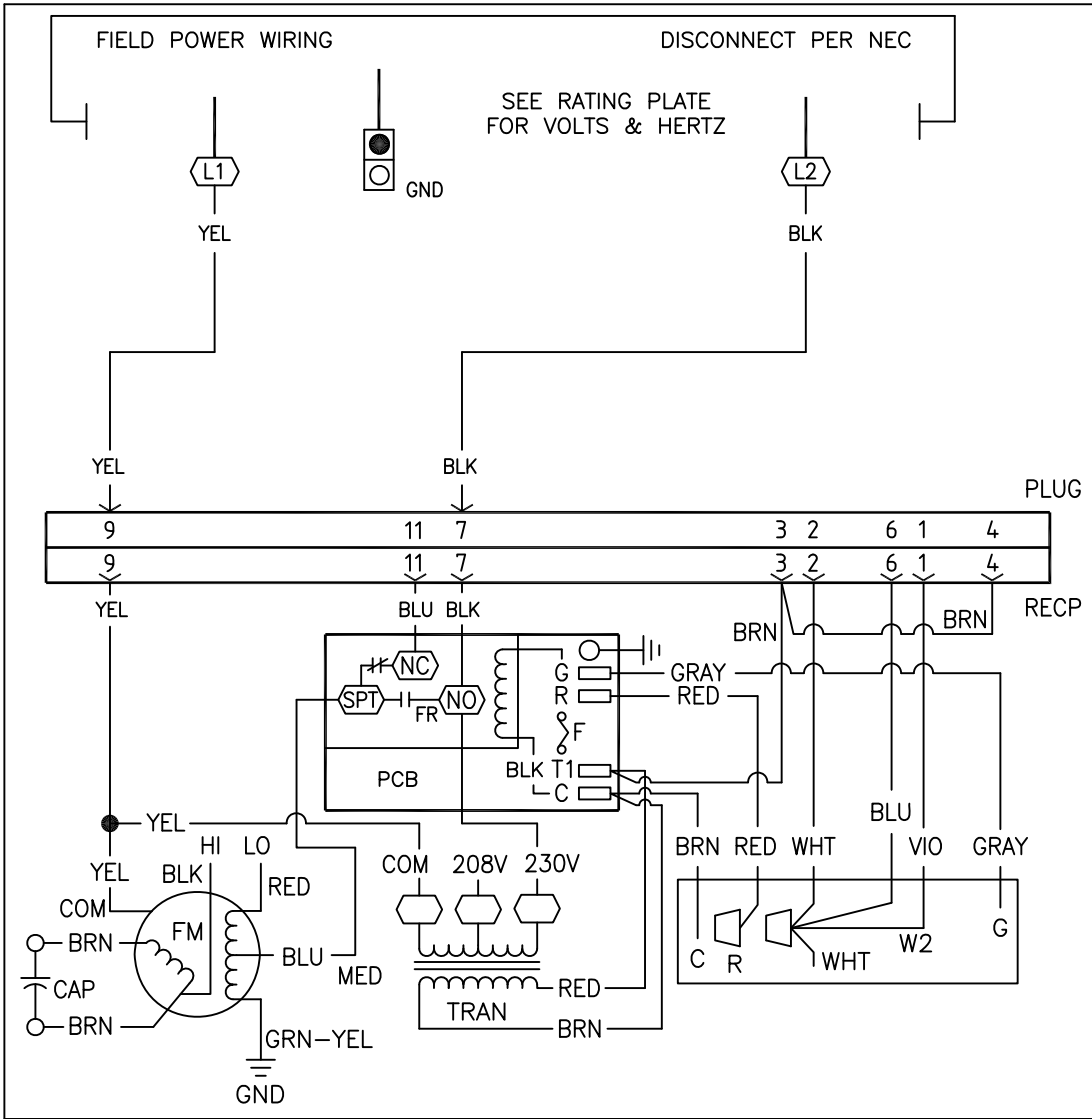

Guide Specification

FB4A HIGH STATIC CHILLED WATER FAN COIL NORMAL COOLING CAPACITY 1 TO 6 TON, ELECTRIC HEATER OPTION (FIELD INSTALATION) 500:2000 CFM

Carrier MODEL NUMBERS FB4A GENERAL

SYSTEM DESCRIPTION

The fan coil unit is designed for outdoor (or under ceiling) installation, electrically controlled cooling and heating (option). Unit shall be designed for vertical and horizontal installation. Standard unit shall include permanent filter with aluminum frame. Unit shall be designed for medium and high external static pressure up to 0.7 inch water.

QUALITY ASSURANCE

- Unit shall be rated in accordance with ARI standard # 410/91.
- Installation and adhesive shall meet NFPA90A requirements for flame spread and smoke generation.
- Unit casing shall be capable of withstanding 500 hour salt spray exposure per ASTM B117 (scribed specimen).
- Unit shall be manufactured in facility registered to ISO9001:2000/BS5750, part2.

PRODUCTS

A. The unit shall be factory assembled single piece cooling unit, with optional electric heat (field installation). Unit cabinet shall be constructed of galvanized steel bonderized and powder painted

enamel finish. The unit shall be insulated with rubber insulation that is 1 inch thickness & 32 kg/m³ density.

B. Unit cabinet panels shall be single skin. Cabinet panels shall be easily removable for service.

C. Unit shall have a permanent type filter with 1 inch aluminum frame. Filter shall be flame retardant polyester fibers. Filters shall be accessible through an access panel.

D. Units shall have high impact thermal plastic sloped condensate pan. Unit shall have primary and secondary drain connection with brass inserts. Unit shall have additional external drain pan for the coil connection condensate water.

E. The unit fan wheel shall be directly connected to the motor. The fan wheel shall be made from steel with a corrosion resistance finish, it shall be a dynamically balanced and double inlet forward curved blades. Unit fan wheel chamber shall be made from galvanized steel.

F. Unit coil shall have aluminum fins mechanically bonded to seamless smooth copper tubes with all joints brazed. Unit coil shall be accessible through an access panel for cleaning. The coil connection shall be sweat type.

G. The unit fan motor shall have permanently lubricated sleeve bearing. The motor shall have overload protection and B class insulation. Unit shall have multiple electric entries for more flexibility.

I. Unit control board shall be 24 VAC and UL listed.

NOTES

FB4A

NOTES



Turn to the Experts.™

Manufacturer reserves the right to discontinue, or change at any time, specifications or designs without notice and without incurring obligations