

**42TW (50/60 Hz)
Chilled Water
Fan Coil Unit
300 Thru 1600 CFM**



Turn to the Experts.™

Product Data

The 42TW chilled water fan coil units are available in 8 sizes with an airflow range from 300 CFM to 1600 CFM. Each size is available with a 3 or 4 row coil. The 3-row coil is available as a 2-pipe system only, while the 4-row coil is available as a 2 or 4 pipe. Each unit is designed to occupy a minimum space. No complex system controls are required for Carrier fan coil units. Piping, drain, and wiring connections are readily accessible and mounting holes and slots are pre-drilled to save installation time and field labor expense.

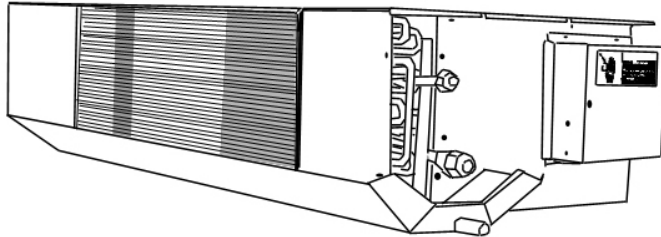

42TW Series

Features/Benefits

- Integrated V Shaped drain pan minimize wet surface for excellent air quality and no auxiliary drain pan required under fixtures.
- The drain pan is polyester powder coated for extra protection.
- Piping connection are field exchangeable; Standard right hand side.
- Left hand connection option is available.
- Direct drive forward curved centrifugal fan.
- 3 speed high efficiency motor with B class insulation.
- Standard galvanized sheet metal casing.
- Low unit height suitable for low false ceiling application.
- Washable aluminum filter.
- Factory installed heater option.
- Easy installation and maintenance.
- ½ inch thickness internal insulation with 24 kg/m³ density.
- Low noise level suitable for all application.
- Plastic blower and blower housing.
- Sweat connections for easy installation and maintenance.
- Thermostat option is available.
- 24 v transformer option is available for the valve package.

42TW Series is designed for Medium external static pressure, to 0.25 inches water (63 Pa) in low false ceiling applications with cooling capacity, to 60 KBtu/Hr (17.6).

42TW is designed for ease of service in under ceiling applications. A carton template for easy location of mounting hardware simplifies installation.

Coils are made of double wavy aluminum fins mechanically bonded to copper tubes for superior heat transfer.

Direct drive forward curved centrifugal fan attached to 3-speed high efficiency motors. Galvanized sheet metal casing protects against rust and drain pan is polyester powder coated for extra protection.

An integral V- Shaped drain pan minimizes wet surface, this minimizes residual water during off

cycles and inhibits the growth of bacteria that may cause smells.

Electrical heater and 3-speed heat/cool thermostat 220 v are available options while washable Aluminum filters are standard feature.

Piping connections position (RH/LH) is optional, also it is field interchangeable to suite various applications.

Table of Contents

	Page
• Model Numbers & Nomenclature.....	3
• Physical Data.....	4,5
• Base Unit Dimension.....	6
• Performance Data.....	7-15
• Fan Performance.....	16,17
• Sound Data.....	18
• Application Data.....	19,20
• Typical Wiring Schematic.....	21
• Options & Accessories.....	22
• Guide Specification.....	23

Model Number Nomenclature

The 42TW chilled water fan coil units are available in 8 sizes with an air flow range from 300 to 1600 CFM. Each size is available with a 3 or 4 row coil. The 3-row coil is available as a 2-pipe system only, while the 4-row coil is available as a 2 or 4 pipe.

Model numbering and nomenclature are as follows:

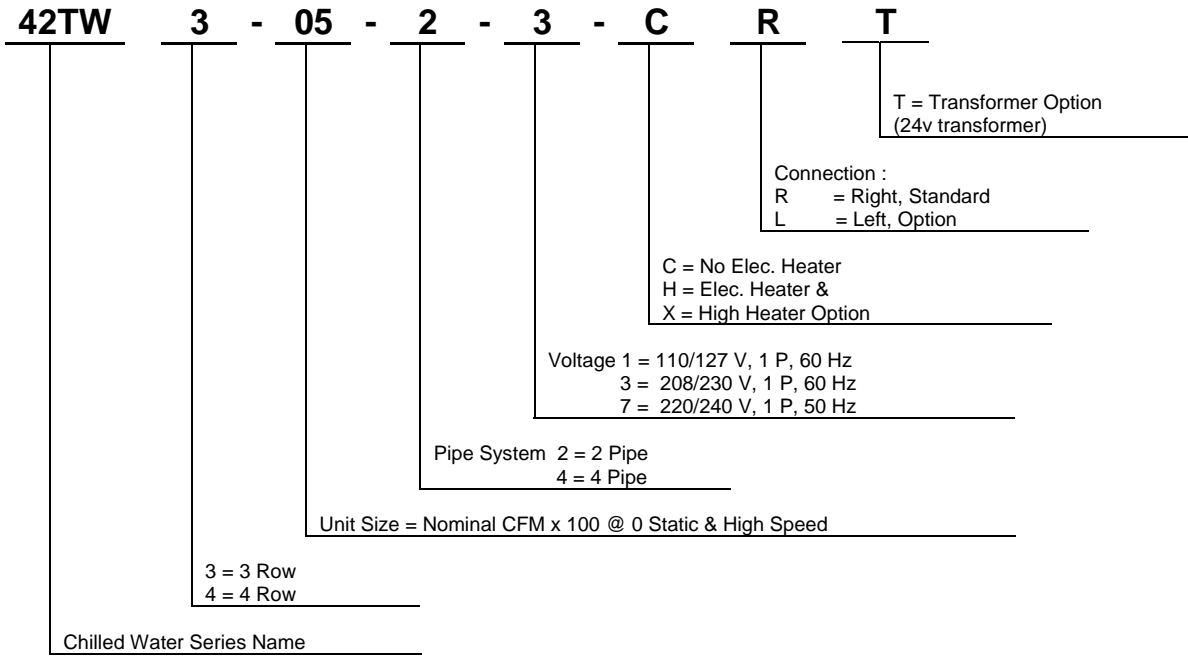

Quality Assurance



0410019950420

Approvals :
 ISO 9001 : 2000
 EN ISO 9001 : 2000
 ANSI/ASQC Q9001 : 2000

Physical Data - 42TW 3

2-Pipe System

Model 42TW3	Size							
	03	05	06	07	09	11	12	16
CFM*	348	592	692	780	883	1181	1385	1572
Cooling Capacity (kw)*	3.4	6.1	7.5	8.9	9.9	11.5	14.5	16.9
Colling Capacity (kbtuh)	11.7	20.7	25.6	30.4	33.8	39.2	49.5	57.7
SHR	0.75	0.74	0.72	0.71	0.71	0.75	0.73	0.73
Normal Elec.Heater (Option) watts	1.5			2	2.5	3	4	
High Elec.Heater (Option) kw	2			2.5	3	4	5	
Power Supply	208-230, 1 ph, 60 Hz / 220-240, 1 ph, 50 Hz / 110-127, 1 ph, 60 Hz							
Motor HP(Nominal)	1/15		1/10			1/15		1/10
Input Watts @ Med Speed & 25 Pa ESP	56	64	70	80	80	130	146	160
Number of Motors	1, 3 Speed					2, 3 Speed		
Coil Material	Smooth copper tubes/ Aluminum fins with double wavey fin							
Coil Face Area, m²	0.11	0.15	0.21	0.26	0.31	0.31	0.44	0.52
Coil Connection Type	Sweat Type							
Coil Connection Size	5/8 Inch				7/8 Inch			
Number of Rows	3							
Fin Denisty/ Inch	14							
Drain Diameter	5/8 Inch							
Blower type	Direct drive forward curved centerifugal fan							
Blower Number	1	2				4		
Blower Diameter / Width, mm	156/220	156/170	156/220			156/170	156/220	
Filter Type	Washable Aluminum Filter							
Width, mm	640	800	1010	1220	1430	1430	1430	1640
Depth, mm	590							
Height, mm	275					375		
Net Weight, kg	18	23	28	32	39	43	49	56

* At 26.7/19 c approach 6.7c water inlet/12.7c water outlet, High speed @ 0 Static

Physical Data - 42TW 4

2-Pipe System

Model 42TW4	Size							
	03	04	05	06	08	10	11	14
CFM*	313	533	623	702	795	1065	1247	1416
Cooling Capacity (kw)*	3.8	6.2	7.7	9.0	9.9	12.7	15.7	17.6
Colling Capacity (kbtuh)	13.0	21.0	26.3	30.8	33.7	43.3	53.6	60.1
SHR	0.69	0.71	0.69	0.69	0.69	0.7	0.68	0.69
Normal Elec.Heater (Option) kw	1.5			2	2.5	3	4	
High Elec.Heater (Option) kw	2			2.5	3	4	5	
Power Supply	208-230, 1 ph, 60 Hz / 220-240, 1 ph, 50 Hz / 110-127, 1 ph, 60 Hz							
Motor HP (Nominal)	1/15			1/10		1/15		1/10
Input Watts (Med Speed, 25 Pa ESP)	52	60	65	75	75	121	136	150
Number of Motors	1, 3 Speed					2, 3 Speed		
Coil Material	Smooth copper tubes/ Aluminum fins with double wavy fin							
Coil Face Area	0.11	0.15	0.21	0.26	0.31	0.31	0.44	0.52
Coil Connection Type	Sweat Type							
Coil Connection Size	5/8 Inch				7/8 Inch			
Number of Rows	4							
Fin Denisty/ Inch	14							
Drain Diameter	5/8 Inch							
Blower type	Direct drive forward curved centerifugal fan							
Blower Number	1	2				4		
Blower Diameter / Width	156/220	156/170	156/220		156/170		156/220	
Filter Type	Washable Aluminum Filter							
Width	640	800	1010	1220	1430	1430	1430	1640
Depth	590							
Height	275						375	
Net Weight	19	24	29	33	41	45	51	58

* At 26.7/19 c approach 6.7c water inlet/12.7c water outlet, High speed @ 0 Static

4-Pipe System

Model 42TW4	Size							
	03	04	05	06	08	10	11	14
CFM*	313	533	623	702	795	1065	1247	1416
Cooling Capacity (kw)*	3.4	5.3	6.9	8.0	8.9	11.2	14.1	15.9
Colling Capacity (kbtuh)	11.6	18.1	23.5	27.3	30.4	38.2	48.1	54.3
Heating Capacity (kw)**	2.9	5.5	6.8	7.9	9.4	12.2	13.9	17.5
Heating Capacity (kbtuh)	9.9	18.8	23.2	27.0	32.1	41.6	47.4	59.7
Power Supply	208-230, 1 ph, 60 Hz / 220-240, 1 ph, 50 Hz / 110-127, 1 ph, 60 Hz							
Motor HP (Nominal)	1/15			1/10		1/15		1/10
	52	60	65	75	75	121	136	150
Number of Motors	1, 3 Speed					2, 3 Speed		
Coil Material	Smooth copper tubes/ Aluminum fins with double wavy fin							
Coil Face Area	0.11	0.15	0.21	0.26	0.31	0.31	0.44	0.52
Coil Connection Type	Sweat Type							
Coil Connection Size Cool & Heat	3/4 Inch & 5/8 Inch							
Number of Rows	4							
Fin Denisty/ Inch	14							
Drain Diameter	5/8 Inch							
Blower type	Direct drive forward curved centerifugal fan							
Blower Number	1	2				4		
Blower Diameter / Width	156/220	156/170	156/220		156/170		156/220	
Filter Type	Washable Aluminum Filter							
Width	640	800	1010	1220	1430	1430	1430	1640
Depth	590							
Height	275						375	
Net Weight	19	24	29	33	41	45	51	58

* At 26.7/19 c approach 6.7c water inlet/12.7c water outlet, High speed @ 0 Static

** At 20 /14 c approach 70c water inlet/61.6c water outlet, High speed @ 0 Static

Base Unit Dimentions

Notes:

- The piping connections drain pan outlet and control box are located on the right hand side facing the airflow as factory standard, They however can be relocated to the left hand side facing air flow in the field when needed.
- Unit should be installed for horizontal discharge only. Suspend horizontally using the factory-provided holes located at the topside flanges of the unit.

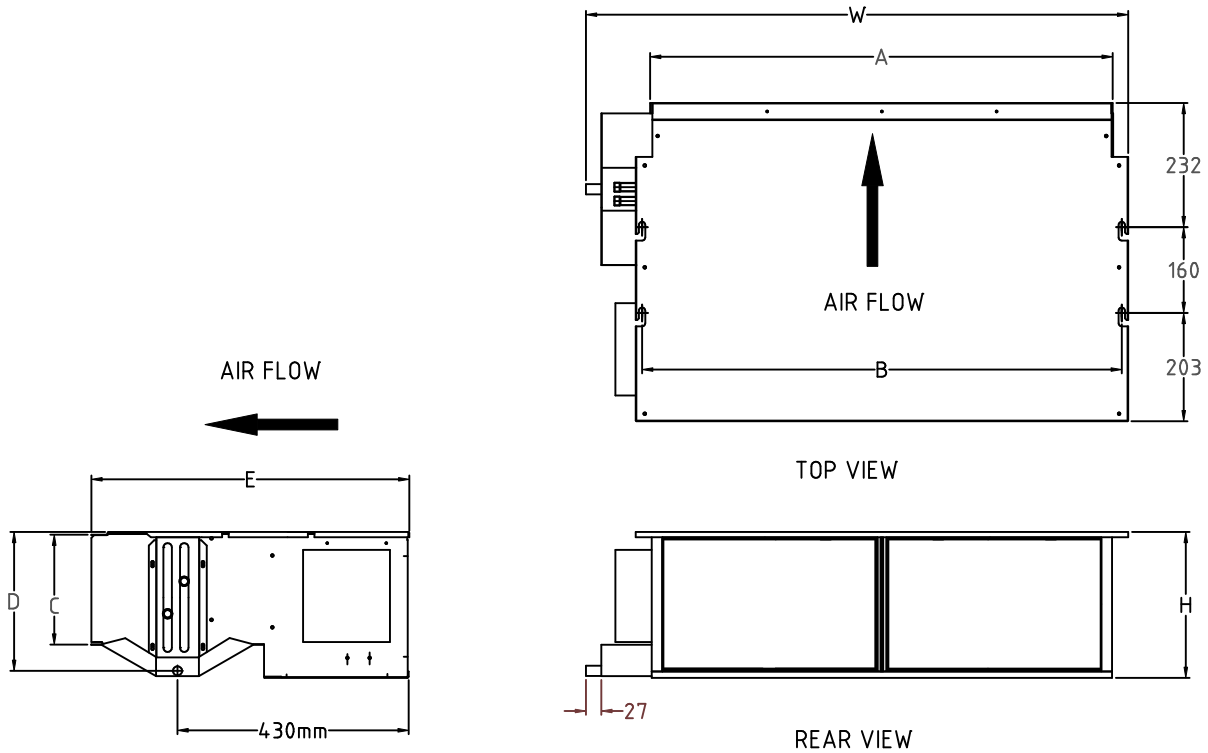

All Dimensions in mm		H	E	W	A	B	C	D
42TW3-03	42TW4-03	275	590	640	487	525	206	260
42TW3-05	42TW4-04	275	590	800	647	685	206	260
42TW3-06	42TW4-05	275	590	1010	857	895	206	260
42TW3-07	42TW4-06	275	590	1220	1067	1105	206	260
42TW3-09	42TW4-08	275	590	1430	1277	1315	206	260
42TW3-11	42TW4-10	275	590	1430	1277	1315	206	260
42TW3-12	42TW4-11	375	590	1430	1277	1315	308	362
42TW3-16	42TW4-14	375	590	1640	1487	1525	308	362

Performance Data

POWER CONSUMPTION 42TW 3ROW

External Static Pressure		@ 0 Pa ESP			@ 25 Pa ESP			@ 50 Pa ESP		
Motor Speed		Hi	Med	Low	Hi	Med	Low	Hi	Med	Low
42TW3-03	Amps	0.40	0.35	0.30	0.34	0.28	0.24	0.30	0.25	0.20
	Watts	80	70	60	68	56	48	60	50	40
42TW3-05	Amps	0.45	0.40	0.35	0.37	0.32	0.27	0.33	0.28	0.22
	Watts	90	80	70	74	64	54	66	56	44
42TW3-06	Amps	0.55	0.45	0.35	0.45	0.35	0.27	0.40	0.30	0.22
	Watts	110	90	70	90	70	54	80	60	44
42TW3-07	Amps	0.60	0.50	0.40	0.50	0.40	0.30	0.45	0.35	0.25
	Watts	120	100	80	100	80	60	90	70	50
42TW3-09	Amps	0.60	0.50	0.40	0.50	0.40	0.30	0.45	0.35	0.25
	Watts	120	100	80	100	80	60	90	70	50
42TW3-11	Amps	0.90	0.80	0.70	0.75	0.65	0.55	0.65	0.55	0.45
	Watts	180	160	140	150	130	110	130	110	90
42TW3-12	Amps	1.10	0.90	0.70	0.90	0.73	0.55	0.80	0.62	0.45
	Watts	220	180	140	180	146	110	160	124	90
42TW3-16	Amps	1.20	1.00	0.80	1.00	0.80	0.62	0.80	0.70	0.50
	Watts	240	200	160	200	160	124	160	140	100

Note: For 220V, 1 Phase Motor.

POWER CONSUMPTION 42TW 4ROW

External Static Pressure		@ 0 Pa ESP			@ 25 Pa ESP			@ 50 Pa ESP		
Motor Speed		Hi	Med	Low	Hi	Med	Low	Hi	Med	Low
42TW4-03	Amps	0.37	0.33	0.28	0.33	0.27	0.23	0.29	0.24	0.20
	Watts	73	64	55	64	52	45	57	48	38
42TW4-04	Amps	0.42	0.37	0.33	0.36	0.31	0.26	0.32	0.27	0.22
	Watts	82	73	64	69	60	50	63	53	42
42TW4-05	Amps	0.51	0.42	0.33	0.43	0.34	0.26	0.39	0.29	0.22
	Watts	100	82	64	84	65	50	76	57	42
42TW4-06	Amps	0.56	0.47	0.37	0.48	0.38	0.29	0.44	0.34	0.24
	Watts	109	91	73	93	75	56	86	67	48
42TW4-08	Amps	0.56	0.47	0.37	0.48	0.38	0.29	0.44	0.34	0.24
	Watts	109	91	73	93	75	56	86	67	48
42TW4-10	Amps	0.84	0.75	0.65	0.72	0.62	0.53	0.64	0.54	0.44
	Watts	164	145	127	140	121	103	124	105	86
42TW4-11	Amps	1.03	0.84	0.65	0.86	0.70	0.53	0.78	0.61	0.44
	Watts	200	164	127	168	136	103	152	118	86
42TW4-14	Amps	1.12	0.93	0.75	0.96	0.77	0.60	0.78	0.68	0.49
	Watts	218	182	145	187	150	116	152	133	95

Note: For 220V, 1 Phase Motor.

Performance Data

42TW – 3 ROW – Cooling.

Rating: 0 Pa External Static Pressure	Fan Speed	42TW3 - 03 - 2			42TW3 - 05 - 2			42TW3 - 06 - 2			42TW3 - 07 - 2		
		High	Med.	Low	High	Med.	Low	High	Med.	Low	High	Med.	Low
Capacity (KW)		3.42	3.12	2.91	6.06	5.39	4.76	7.49	6.39	6.20	8.93	8.04	7.25
Capacity (KBtu/Hr)		11.67	10.65	9.93	20.68	18.39	16.24	25.56	21.80	21.15	30.47	27.43	24.74
CFM		348	303	274	592	498	408	692	586	548	780	691	607
L/sec Air		164	143	129	279	235	193	327	276	259	368	326	286
SHR(Sensible/Total)		75%	74%	73%	74%	72%	70%	72%	72%	71%	71%	71%	70%
Air DB Ent		26.7	26.7	26.7	26.7	26.7	26.7	26.7	26.7	26.7	26.7	26.7	26.7
Air WB Ent		19.4	19.4	19.4	19.4	19.4	19.4	19.4	19.4	19.4	19.4	19.4	19.4
Air DB Lvng.		13.8	13.3	13.1	13.5	13.0	12.3	13.0	12.9	12.5	12.5	12.3	12.1
Air WB Lvng.		13.3	13.0	12.8	13.1	12.7	12.1	12.6	12.6	12.3	12.1	12.0	11.8
N Circuits		2	2	2	2	2	2	3	3	3	4	4	4
Face Tubes		10	10	10	10	10	10	10	10	10	10	10	10
Water In C		6.7	6.7	6.7	6.7	6.7	6.7	6.7	6.7	6.7	6.7	6.7	6.7
Water Lvng C		12.7	12.7	12.7	12.7	12.7	12.7	12.7	12.7	12.7	12.7	12.7	12.7
Gal/Min		2.16	1.96	1.84	3.82	3.40	3.00	4.72	4.03	3.91	5.63	5.07	4.58
L/sec Water		0.14	0.12	0.12	0.24	0.21	0.19	0.30	0.25	0.25	0.36	0.32	0.29
DP PSI		2.5	2.1	1.9	9.4	7.6	6.1	5.7	4.3	4.1	9.5	7.9	6.6
DP K Pa		17.4	14.8	13.1	64.7	52.6	42.3	39.4	29.9	28.3	65.5	54.6	45.6

25 Pa. External Static Pressure	Fan Speed	High	Med.	Low	High	Med.	Low	High	Med.	Low	High	Med.	Low
		High	Med.	Low	High	Med.	Low	High	Med.	Low	High	Med.	Low
Capacity (KW)		3.23	2.81	2.50	5.51	4.59	4.08	7.09	5.90	5.32	8.52	7.17	6.23
Capacity (KBtu/Hr)		11.02	9.59	8.53	18.80	15.66	13.92	24.19	20.13	18.15	29.07	24.46	21.26
CFM		320	263	224	515	398	332	640	524	447	732	592	497
L/sec Air		151	124	106	243	188	157	302	247	211	345	279	235
SHR		74%	73%	72%	72%	71%	69%	72%	72%	70%	70%	70%	69%
Air DB Ent		26.7	26.7	26.7	26.7	26.7	26.7	26.7	26.7	26.7	26.7	26.7	26.7
Air WB Ent		19.4	19.4	19.4	19.4	19.4	19.4	19.4	19.4	19.4	19.4	19.4	19.4
Air DB Lvng.		13.6	13.0	12.7	13.1	12.4	11.8	12.8	12.6	12.1	12.3	11.9	11.6
Air WB Lvng.		13.1	12.7	12.4	12.7	12.1	11.6	12.4	12.3	11.8	11.9	11.6	11.4
Water In C		6.7	6.7	6.7	6.7	6.7	6.7	6.7	6.7	6.7	6.7	6.7	6.7
Water Lvng C		12.7	12.7	12.7	12.7	12.7	12.7	12.7	12.7	12.7	12.7	12.7	12.7
Gal/Min		2.04	1.77	1.58	3.47	2.89	2.57	4.47	3.72	3.36	5.38	4.52	3.93
L/sec Water		0.13	0.11	0.10	0.22	0.18	0.16	0.28	0.24	0.21	0.34	0.29	0.25
DP PSI		2.3	1.8	1.5	7.9	5.7	4.7	5.2	3.8	3.2	8.8	6.5	5.1
DP K Pa		15.8	12.3	10.2	54.7	39.6	32.3	35.8	26.1	21.8	60.4	44.6	35.0

50 Pa. External Static Pressure	Fan Speed	High	Med.	Low	High	Med.	Low	High	Med.	Low	High	Med.	Low
		High	Med.	Low	High	Med.	Low	High	Med.	Low	High	Med.	Low
Capacity (KW)		2.87	2.38	1.78	4.78	3.88	3.04	6.27	5.00	3.83	7.42	5.93	4.96
Capacity (KBtu/Hr)		9.79	8.12	6.07	16.31	13.24	10.37	21.39	17.06	13.07	25.32	20.23	16.92
CFM		271	211	147	423	318	229	541	421	294	607	464	373
L/sec Air		128	99	69	199	150	108	255	199	139	286	219	176
SHR		73%	71%	70%	71%	70%	67%	71%	70%	68%	69%	68%	68%
Air DB Ent		26.7	26.7	26.7	26.7	26.7	26.7	26.7	26.7	26.7	26.7	26.7	26.7
Air WB Ent		19.4	19.4	19.4	19.4	19.4	19.4	19.4	19.4	19.4	19.4	19.4	19.4
Air DB Lvng.		13.1	12.5	11.9	12.6	11.8	11.0	12.3	12.1	11.2	11.8	11.4	11.0
Air WB Lvng.		12.7	12.2	11.7	12.2	11.5	10.8	12.0	11.8	10.9	11.5	11.1	10.7
Water In C		6.7	6.7	6.7	6.7	6.7	6.7	6.7	6.7	6.7	6.7	6.7	6.7
Water Lvng C		12.7	12.7	12.7	12.7	12.7	12.7	12.7	12.7	12.7	12.7	12.7	12.7
Gal/Min		1.81	1.50	1.12	3.02	2.45	1.92	3.95	3.16	2.42	4.68	3.74	3.13
L/sec Water		0.11	0.09	0.07	0.19	0.15	0.12	0.25	0.20	0.15	0.30	0.24	0.20
DP PSI		1.9	1.3	0.8	6.2	4.3	2.8	4.2	2.8	1.8	6.9	4.7	3.4
DP K Pa		12.8	9.26	5.31	42.7	29.6	19.4	28.9	19.6	12.3	47.4	32.1	23.5

Note: Table intended for quick selection, for other conditions use selection software.

Performance Data

42TW – 3 ROW – Cooling (Cont.)

Rating: 0 Pa External Static Pressure	Fan Speed	42TW3 - 09 - 2			42TW3 - 11 - 2			42TW3 - 12 - 2			42TW3 - 16 - 2		
		High	Med.	Low	High	Med.	Low	High	Med.	Low	High	Med.	Low
Capacity (KW)		9.90	8.89	8.02	11.5	10.3	8.90	14.5	13.8	12.6	16.9	15.9	14.3
Capacity (KBtu/Hr)		33.78	30.33	27.36	39.24	35.14	30.37	49.47	47.09	42.99	57.66	54.25	48.79
CFM		883	756	659	1181	995	815	1385	1172	1096	1572	1383	1214
L/sec Air		417	357	311	557	469	385	654	553	517	742	652	573
SHR(Sensible/Total)		71%	70%	69%	75%	74%	72%	73%	70%	71%	73%	70%	70%
Air DB Ent		26.7	26.7	26.7	26.7	26.7	26.7	26.7	26.7	26.7	26.7	26.7	26.7
Air WB Ent		19.4	19.4	19.4	19.4	19.4	19.4	19.4	19.4	19.4	19.4	19.4	19.4
Air DB Lvng.		12.7	12.2	11.9	13.9	13.3	12.9	13.3	12.2	12.4	13.0	12.5	12.2
Air WB Lvng.		12.3	11.9	11.6	13.4	13.0	12.6	12.9	11.9	12.2	12.6	12.2	12.0
N Circuits		4	4	4	5	5	5	6	6	6	7	7	7
Face Tubes		10	10	10	10	10	10	14	14	14	14	14	14
Water In C		6.7	6.7	6.7	6.7	6.7	6.7	6.7	6.7	6.7	6.7	6.7	6.7
Water Lvng C		12.7	12.7	12.7	12.7	12.7	12.7	12.7	12.7	12.7	12.7	12.7	12.7
Gal/Min		6.25	5.61	5.05	7.26	6.49	5.61	9.12	8.72	7.94	10.67	10.04	9.02
L/sec Water		0.39	0.35	0.32	0.46	0.41	0.35	0.58	0.55	0.50	0.67	0.63	0.57
DP PSI		6.0	5.0	4.2	4.3	3.5	2.7	5.3	4.9	4.2	5.4	4.8	4.0
DP K Pa		41.5	34.4	28.7	29.5	24.3	18.8	36.7	34	28.9	37	33.3	27.7

25 Pa. External Static Pressure	Fan Speed	High	Med.	Low	High	Med.	Low	High	Med.	Low	High	Med.	Low
		High	Med.	Low	High	Med.	Low	High	Med.	Low	High	Med.	Low
Capacity (KW)		9.12	7.74	6.77	10.5	8.78	7.67	13.7	12.7	10.8	16.0	14.2	12.3
Capacity (KBtu/Hr)		31.12	26.41	23.10	35.83	29.96	26.17	46.74	43.33	36.85	54.59	48.45	41.97
CFM		789	630	531	1031	796	665	1281	1048	893	1452	1184	995
L/sec Air		372	297	251	486	376	314	605	495	422	685	559	469
SHR		71%	69%	68%	74%	72%	71%	73%	70%	70%	72%	70%	69%
Air DB Ent		26.7	26.7	26.7	26.7	26.7	26.7	26.7	26.7	26.7	26.7	26.7	26.7
Air WB Ent		19.4	19.4	19.4	19.4	19.4	19.4	19.4	19.4	19.4	19.4	19.4	19.4
Air DB Lvng.		12.4	11.8	11.4	13.5	12.7	12.3	13.1	11.9	11.9	12.8	12.0	11.7
Air WB Lvng.		12.0	11.5	11.2	13.1	12.4	12.1	12.7	11.6	11.7	12.4	11.7	11.5
Water In C		6.7	6.7	6.7	6.7	6.7	6.7	6.7	6.7	6.7	6.7	6.7	6.7
Water Lvng C		12.7	12.7	12.7	12.7	12.7	12.7	12.7	12.7	12.7	12.7	12.7	12.7
Gal/Min		5.75	4.88	4.27	6.60	5.54	4.83	8.63	8.02	6.81	10.08	8.94	7.75
L/sec Water		0.36	0.31	0.27	0.42	0.35	0.31	0.54	0.51	0.43	0.64	0.56	0.49
DP PSI		5.2	3.9	3.1	3.6	2.7	2.1	4.8	4.3	3.2	4.9	3.9	3.1
DP K Pa		36.0	27.1	21.4	25	18.4	14.6	33.4	29.4	22.1	33.5	27.2	21.3

50 Pa. External Static Pressure	Fan Speed	High	Med.	Low	High	Med.	Low	High	Med.	Low	High	Med.	Low
		High	Med.	Low	High	Med.	Low	High	Med.	Low	High	Med.	Low
Capacity (KW)		7.97	6.54	5.19	9.08	7.44	5.71	12.1	10.7	7.71	14.0	11.8	9.81
Capacity (KBtu/Hr)		27.19	22.31	17.71	30.98	25.39	19.48	41.29	36.51	26.31	47.77	40.26	33.47
CFM		659	509	383	846	637	457	1082	842	587	1214	927	746
L/sec Air		311	240	181	399	301	216	511	397	277	573	437	352
SHR		70%	68%	67%	73%	71%	69%	72%	69%	68%	71%	68%	68%
Air DB Ent		26.7	26.7	26.7	26.7	26.7	26.7	26.7	26.7	26.7	26.7	26.7	26.7
Air WB Ent		19.4	19.4	19.4	19.4	19.4	19.4	19.4	19.4	19.4	19.4	19.4	19.4
Air DB Lvng.		11.9	11.3	10.7	13.0	12.2	11.6	12.6	11.4	11.1	12.4	11.5	11.1
Air WB Lvng.		11.6	11.0	10.5	12.6	11.9	11.4	12.3	11.1	10.8	12.0	11.2	10.9
Water In C		6.7	6.7	6.7	6.7	6.7	6.7	6.7	6.7	6.7	6.7	6.7	6.7
Water Lvng C		12.7	12.7	12.7	12.7	12.7	12.7	12.7	12.7	12.7	12.7	12.7	12.7
Gal/Min		5.03	4.13	3.27	5.73	4.69	3.60	7.64	6.76	4.86	8.83	7.41	6.18
L/sec Water		0.32	0.26	0.21	0.36	0.30	0.23	0.48	0.43	0.31	0.56	0.47	0.39
DP PSI		4.1	2.9	2.0	2.8	2.0	1.3	3.9	3.2	1.8	3.9	2.9	2.1
DP K Pa		28.4	20.2	13.5	19.6	13.8	8.82	27.0	21.8	12.5	26.7	19.7	14.4

Note: Table intended for quick selection, for other conditions use selection software.

Performance Data

42TW – 4 ROW – 2 PIPE – Cooling.

Rating: 0 Pa External Static Pressure	Fan Speed	42TW4 - 03 - 2			42TW4 - 04 - 2			42TW4 - 05 - 2			42TW4 - 06 - 2		
		High	Med.	Low	High	Med.	Low	High	Med.	Low	High	Med.	Low
Capacity (KW)		3.84	3.48	3.24	6.17	5.4	4.63	7.74	6.82	6.58	8.95	8.20	7.43
Capacity (KBtu/Hr)		13.1	11.87	11.05	21.05	18.42	15.8	26.41	23.27	22.45	30.54	27.98	25.35
CFM		313	273	247	533	450	368	623	527	494	702	623	548
L/sec Air		148	129	116	251	212	174	294	249	233	331	294	259
SHR(Sensible/Total)		69%	68%	67%	71%	70%	69%	69%	68%	67%	68%	68%	67%
Air DB Ent		26.7	26.7	26.7	26.7	26.7	26.7	26.7	26.7	26.7	26.7	26.7	26.7
Air WB Ent		19.4	19.4	19.4	19.4	19.4	19.4	19.4	19.4	19.4	19.4	19.4	19.4
Air DB Lvng.		11.9	11.4	11.2	12.4	12.0	11.5	11.7	11.3	11.0	11.4	11.1	10.8
Air WB Lvng.		11.6	11.3	11.1	12.2	11.9	11.4	11.5	11.1	10.9	11.2	10.9	10.7
N Circuits		2	2	2	3	3	3	3	3	3	4	4	4
Face Tubes		10	10	10	10	10	10	10	10	10	10	10	10
Water In C		6.7	6.7	6.7	6.7	6.7	6.7	6.7	6.7	6.7	6.7	6.7	6.7
Water Lvng C		12.7	12.7	12.7	12.7	12.7	12.7	12.7	12.7	12.7	12.7	12.7	12.7
Gal/Min		2.42	2.19	2.04	3.89	3.40	2.92	4.88	4.29	4.15	5.64	5.17	4.68
L/sec Water		0.15	0.14	0.13	0.25	0.21	0.18	0.31	0.27	0.26	0.36	0.33	0.30
DP PSI		4.1	3.5	3.1	4.2	3.3	2.6	8.1	6.5	6.1	5.8	5.0	4.2
DP K Pa		28.5	23.9	21.2	29	23	17.7	55.8	44.5	42.0	39.7	34.3	28.8

25 Pa. External Static Pressure	Fan Speed	High Med. Low			High Med. Low			High Med. Low			High Med. Low		
		High	Med.	Low	High	Med.	Low	High	Med.	Low	High	Med.	Low
Capacity (KW)		3.66	3.14	2.77	5.65	4.61	4.00	7.41	6.36	5.67	8.67	7.38	6.41
Capacity (KBtu/Hr)		12.49	10.71	9.451	19.28	15.73	13.65	25.28	21.7	19.35	29.58	25.18	21.87
CFM		295	242	206	474	366	305	589	483	411	673	545	457
L/sec Air		139	114	97	224	173	144	278	228	194	318	257	216
SHR		69%	68%	67%	70%	69%	68%	69%	68%	67%	68%	67%	66%
Air DB Ent		26.7	26.7	26.7	26.7	26.7	26.7	26.7	26.7	26.7	26.7	26.7	26.7
Air WB Ent		19.4	19.4	19.4	19.4	19.4	19.4	19.4	19.4	19.4	19.4	19.4	19.4
Air DB Lvng.		11.7	11.3	10.9	12.1	11.5	11.1	11.6	11.1	10.6	11.3	10.8	10.4
Air WB Lvng.		11.5	11.1	10.8	11.9	11.3	11.0	11.4	10.9	10.5	11.1	10.6	10.3
Water In C		6.7	6.7	6.7	6.7	6.7	6.7	6.7	6.7	6.7	6.7	6.7	6.7
Water Lvng C		12.7	12.7	12.7	12.7	12.7	12.7	12.7	12.7	12.7	12.7	12.7	12.7
Gal/Min		2.31	1.98	1.75	3.56	2.91	2.52	4.67	4.01	3.58	5.46	4.65	4.05
L/sec Water		0.15	0.12	0.11	0.22	0.18	0.16	0.29	0.25	0.23	0.34	0.29	0.26
DP PSI		3.8	2.9	2.3	3.6	2.5	2.0	7.5	5.7	4.7	5.5	4.1	3.2
DP K Pa		26.2	20	16.1	25.0	17.5	13.7	51.6	39.5	32.4	37.6	28.5	22.3

50 Pa. External Static Pressure	Fan Speed	High Med. Low			High Med. Low			High Med. Low			High Med. Low		
		High	Med.	Low	High	Med.	Low	High	Med.	Low	High	Med.	Low
Capacity (KW)		3.23	2.63	1.93	4.95	3.94	2.98	6.62	5.42	4.07	7.61	6.16	5.13
Capacity (KBtu/Hr)		11.02	8.974	6.585	16.89	13.44	10.17	22.59	18.49	13.89	25.97	21.02	17.5
CFM		255	198	138	397	300	215	509	396	276	570	436	351
L/sec Air		120	93	65	187	141	102	240	187	130	269	206	166
SHR		68%	67%	66%	69%	68%	67%	68%	67%	65%	67%	66%	65%
Air DB Ent		26.7	26.7	26.7	26.7	26.7	26.7	26.7	26.7	26.7	26.7	26.7	26.7
Air WB Ent		19.4	19.4	19.4	19.4	19.4	19.4	19.4	19.4	19.4	19.4	19.4	19.4
Air DB Lvng.		11.5	11.0	10.6	11.6	11.1	10.5	11.2	10.6	9.8	11.0	10.3	9.9
Air WB Lvng.		11.3	10.8	10.5	11.4	10.9	10.4	11.0	10.5	9.7	10.8	10.2	9.8
Water In C		6.7	6.7	6.7	6.7	6.7	6.7	6.7	6.7	6.7	6.7	6.7	6.7
Water Lvng C		12.7	12.7	12.7	12.7	12.7	12.7	12.7	12.7	12.7	12.7	12.7	12.7
Gal/Min		2.04	1.66	1.22	3.12	2.48	1.88	4.17	3.42	2.57	4.79	3.88	3.24
L/sec Water		0.13	0.10	0.08	0.20	0.16	0.12	0.26	0.22	0.16	0.30	0.25	0.20
DP PSI		3.0	2.1	1.2	2.9	1.9	1.2	6.1	4.3	2.6	4.4	3.0	2.2
DP K Pa		21.0	14.7	8.37	19.8	13.3	8.01	42.4	29.9	18.2	30.0	20.8	15.2

Note: Table intended for quick selection, for other conditions use selection software.

Performance Data

42TW – 4 ROW – 2 PIPE – Cooling - (Cont.)

Rating: 0 Pa External Static Pressure	Fan Speed	42TW4 - 08 - 2			42TW4 - 10 - 2			42TW4 - 11 - 2			42TW4 - 14 - 2		
		High	Med.	Low	High	Med.	Low	High	Med.	Low	High	Med.	Low
Capacity (KW)		9.94	8.84	7.95	12.7	11.3	9.61	15.7	13.7	13.0	17.6	16.0	14.5
Capacity (KBtu/Hr)		33.92	30.16	27.13	43.33	38.56	32.79	53.57	46.74	44.36	60.05	54.59	49.47
CFM		795	680	593	1065	897	735	1247	1055	988	1416	1247	1094
L/sec Air		375	321	280	502	423	347	589	498	466	668	588	516
SHR(Sensible/Total)		69%	68%	67%	70%	68%	68%	68%	68%	68%	69%	68%	67%
Air DB Ent		26.7	26.7	26.7	26.7	26.7	26.7	26.7	26.7	26.7	26.7	26.7	26.7
Air WB Ent		19.4	19.4	19.4	19.4	19.4	19.4	19.4	19.4	19.4	19.4	19.4	19.4
Air DB Lvng.		11.6	11.2	10.9	12.1	11.6	11.2	11.6	11.2	11.1	11.7	11.4	11.0
Air WB Lvng.		11.4	11.1	10.8	11.9	11.4	11.1	11.4	11.1	11.0	11.5	11.2	10.9
N Circuits		5	5	5	5	5	5	7	7	7	8	8	8.0
Face Tubes		10	10	10	10	10	10	14	14	14	14	14	14
Water In C		6.7	6.7	6.7	6.7	6.7	6.7	6.7	6.7	6.7	6.7	6.7	6.7
Water Lvng C		12.7	12.7	12.7	12.7	12.7	12.7	12.7	12.7	12.7	12.7	12.7	12.7
Gal/Min		6.27	5.57	5.01	7.99	7.11	6.06	9.89	8.63	8.23	11.11	10.11	9.12
L/sec Water		0.40	0.35	0.32	0.50	0.45	0.38	0.62	0.54	0.52	0.70	0.64	0.58
DP PSI		4.4	3.6	3.0	6.8	5.5	4.2	5.5	4.3	4.0	5.3	4.5	3.7
DP K Pa		30.6	25.0	20.7	46.7	38.1	28.9	37.7	29.7	27.4	36.3	30.8	25.7

25 Pa. External Static Pressure	Fan Speed	High Med. Low			High Med. Low			High Med. Low			High Med. Low		
		High	Med.	Low	High	Med.	Low	High	Med.	Low	High	Med.	Low
Capacity (KW)		9.26	7.79	6.79	11.6	9.62	8.31	15.0	12.8	11.3	16.9	14.4	12.5
Capacity (KBtu/Hr)		31.6	26.58	23.17	39.58	32.82	28.35	51.18	43.67	38.56	57.66	49.13	42.65
CFM		725	581	489	948	732	612	1179	965	822	1336	1089	915
L/sec Air		342	274	231	447	346	289	556	455	388	631	514	432
SHR		68%	67%	67%	69%	68%	67%	68%	67%	67%	69%	68%	67%
Air DB Ent		26.7	26.7	26.7	26.7	26.7	26.7	26.7	26.7	26.7	26.7	26.7	26.7
Air WB Ent		19.4	19.4	19.4	19.4	19.4	19.4	19.4	19.4	19.4	19.4	19.4	19.4
Air DB Lvng.		11.4	10.9	10.5	11.8	11.1	10.8	11.5	11.0	10.6	11.5	11.0	10.7
Air WB Lvng.		11.2	10.7	10.4	11.6	10.9	10.6	11.3	10.9	10.5	11.3	10.9	10.6
Water In C		6.7	6.7	6.7	6.7	6.7	6.7	6.7	6.7	6.7	6.7	6.7	6.7
Water Lvng C		12.7	12.7	12.7	12.7	12.7	12.7	12.7	12.7	12.7	12.7	12.7	12.7
Gal/Min		5.83	4.91	4.28	7.33	6.06	5.24	9.46	8.04	7.12	10.62	9.08	7.89
L/sec Water		0.37	0.31	0.27	0.46	0.38	0.33	0.60	0.51	0.45	0.67	0.57	0.50
DP PSI		3.9	2.9	2.3	5.8	4.2	3.2	5.0	3.8	3.1	4.9	3.7	2.9
DP K Pa		27.0	20.1	15.8	40.2	28.9	22.4	34.8	26.3	21.3	33.6	25.6	20.0

50 Pa. External Static Pressure	Fan Speed	High Med. Low			High Med. Low			High Med. Low			High Med. Low		
		High	Med.	Low	High	Med.	Low	High	Med.	Low	High	Med.	Low
Capacity (KW)		8.24	6.64	5.15	10.1	8.21	6.2	13.4	10.9	8.06	14.9	12	10
Capacity (KBtu/Hr)		28.11	22.66	17.57	34.46	28.01	21.15	45.72	37.19	27.5	50.84	40.94	34.12
CFM		626	479	354	795	599	430	1018	791	551	1141	872	702
L/sec Air		295	226	167	375	282	203	480	373	260	538	411	331
SHR		68%	67%	66%	69%	67%	66%	67%	67%	66%	68%	67%	66%
Air DB Ent		26.7	26.7	26.7	26.7	26.7	26.7	26.7	26.7	26.7	26.7	26.7	26.7
Air WB Ent		19.4	19.4	19.4	19.4	19.4	19.4	19.4	19.4	19.4	19.4	19.4	19.4
Air DB Lvng.		11.1	10.5	10.0	11.4	10.6	10.0	11.1	10.6	9.9	11.2	10.6	10.2
Air WB Lvng.		10.9	10.3	9.9	11.2	10.5	9.9	10.9	10.5	9.8	11.0	10.4	10.1
Water In C		6.7	6.7	6.7	6.7	6.7	6.7	6.7	6.7	6.7	6.7	6.7	6.7
Water Lvng C		12.7	12.7	12.7	12.7	12.7	12.7	12.7	12.7	12.7	12.7	12.7	12.7
Gal/Min		5.20	4.19	3.24	6.39	5.17	3.91	8.44	6.86	5.09	9.39	7.58	6.31
L/sec Water		0.33	0.26	0.20	0.40	0.33	0.25	0.53	0.43	0.32	0.59	0.48	0.40
DP PSI		3.2	2.2	1.4	4.6	3.2	2.0	4.1	2.9	1.7	3.9	2.7	2.0
DP K Pa		22.1	15.3	9.58	31.6	21.9	13.5	28.6	20.0	12.0	27.1	18.7	13.7

Note: Table intended for quick selection, for other conditions use selection software.

Performance Data

42TW – 4 ROW – 4 PIPE – Cooling.

Rating: 0 Pa External Static Pressure	Fan Speed	42TW4 - 03			42TW4 - 04			42TW4 - 05			42TW4 - 06		
		High	Med.	Low	High	Med.	Low	High	Med.	Low	High	Med.	Low
Capacity (KW)		3.37	3.08	2.87	5.33	4.80	4.13	6.93	6.11	5.88	8.03	7.34	6.64
Capacity (KBtu/Hr)		11.5	10.51	9.792	18.19	16.38	14.09	23.65	20.85	20.06	27.4	25.04	22.66
CFM		313	273	247	533	450	368	623	527	494	702	623	548
L/sec Air		148	129	116	251	212	174	294	249	233	331	294	259
SHR(Sensible/Total)		72%	71%	70%	74%	72%	71%	71%	70%	69%	70%	70%	69%
Air DB Ent		26.7	26.7	26.7	26.7	26.7	26.7	26.7	26.7	26.7	26.7	26.7	26.7
Air WB Ent		19.4	19.4	19.4	19.4	19.4	19.4	19.4	19.4	19.4	19.4	19.4	19.4
Air DB Lvng.		13.0	12.6	12.3	13.8	13.2	12.7	12.9	12.5	12.2	12.6	12.3	12.0
Air WB Lvng.		12.8	12.4	12.2	13.5	13.0	12.6	12.6	12.3	12.1	12.4	12.1	11.9
N Circuits		2	2	2	2	2	2	3	3	3	3	3	3
Face Tubes		10	10	10	10	10	10	10	10	10	10	10	10
Water In C		6.7	6.7	6.7	6.7	6.7	6.7	6.7	6.7	6.7	6.7	6.7	6.7
Water Lvng C		12.7	12.7	12.7	12.7	12.7	12.7	12.7	12.7	12.7	12.7	12.7	12.7
Gal/Min		2.13	1.94	1.81	3.36	3.02	2.60	4.37	3.85	3.70	5.06	4.63	4.19
L/sec Water		0.13	0.12	0.11	0.21	0.19	0.16	0.28	0.24	0.23	0.32	0.29	0.26
DP PSI		2.9	2.5	2.2	6.5	5.4	4.2	4.5	3.6	3.3	6.8	5.8	4.9
DP K Pa		20.1	17.1	15.2	44.9	37.3	28.7	30.9	24.7	23.1	46.6	39.9	33.5

25 Pa. External Static Pressure	Fan Speed	42TW4 - 03			42TW4 - 04			42TW4 - 05			42TW4 - 06		
		High	Med.	Low	High	Med.	Low	High	Med.	Low	High	Med.	Low
Capacity (KW)		3.23	2.81	2.50	4.93	4.15	3.60	6.67	5.72	5.11	7.79	6.64	5.78
Capacity (KBtu/Hr)		11.02	9.588	8.53	16.82	14.16	12.28	22.76	19.52	17.44	26.58	22.66	19.72
CFM		295	242	206	474	366	305	589	483	411	673	545	457
L/sec Air		139	114	97	224	173	144	278	228	194	318	257	216
SHR		72%	70%	70%	73%	71%	70%	70%	70%	68%	70%	69%	68%
Air DB Ent		26.7	26.7	26.7	26.7	26.7	26.7	26.7	26.7	26.7	26.7	26.7	26.7
Air WB Ent		19.4	19.4	19.4	19.4	19.4	19.4	19.4	19.4	19.4	19.4	19.4	19.4
Air DB Lvng.		12.9	12.3	11.9	13.4	12.7	12.2	12.7	12.2	11.8	12.5	12.0	11.6
Air WB Lvng.		12.6	12.2	11.8	13.2	12.5	12.1	12.5	12.1	11.6	12.3	11.8	11.5
Water In C		6.7	6.7	6.7	6.7	6.7	6.7	6.7	6.7	6.7	6.7	6.7	6.7
Water Lvng C		12.7	12.7	12.7	12.7	12.7	12.7	12.7	12.7	12.7	12.7	12.7	12.7
Gal/Min		2.04	1.77	1.58	3.11	2.62	2.27	4.20	3.61	3.22	4.91	4.19	3.65
L/sec Water		0.13	0.11	0.10	0.20	0.17	0.14	0.27	0.23	0.20	0.31	0.26	0.23
DP PSI		2.7	2.1	1.8	5.7	4.2	3.3	4.2	3.2	2.6	6.4	4.9	3.8
DP K Pa		18.7	14.6	12.1	39.1	28.9	22.5	28.8	22.1	18.1	44.3	33.5	26.3

50 Pa. External Static Pressure	Fan Speed	42TW4 - 03			42TW4 - 04			42TW4 - 05			42TW4 - 06		
		High	Med.	Low	High	Med.	Low	High	Med.	Low	High	Med.	Low
Capacity (KW)		2.89	2.40	1.79	4.35	3.57	2.75	5.99	4.92	3.73	6.89	5.59	4.68
Capacity (KBtu/Hr)		9.861	8.189	6.107	14.84	12.18	9.383	20.44	16.79	12.73	23.51	19.07	15.97
CFM		255	198	138	397	300	215	509	396	276	570	436	351
L/sec Air		120	93	65	187	141	102	240	187	130	269	206	166
SHR		71%	70%	68%	71%	70%	68%	70%	68%	67%	69%	68%	67%
Air DB Ent		26.7	26.7	26.7	26.7	26.7	26.7	26.7	26.7	26.7	26.7	26.7	26.7
Air WB Ent		19.4	19.4	19.4	19.4	19.4	19.4	19.4	19.4	19.4	19.4	19.4	19.4
Air DB Lvng.		12.5	11.9	11.2	13.0	12.1	11.4	12.3	11.8	10.9	12.1	11.4	11.0
Air WB Lvng.		12.3	11.7	11.1	12.7	12.0	11.3	12.1	11.6	10.8	11.8	11.3	10.9
Water In C		6.7	6.7	6.7	6.7	6.7	6.7	6.7	6.7	6.7	6.7	6.7	6.7
Water Lvng C		12.7	12.7	12.7	12.7	12.7	12.7	12.7	12.7	12.7	12.7	12.7	12.7
Gal/Min		1.82	1.51	1.13	2.74	2.25	1.73	3.78	3.10	2.35	4.34	3.53	2.95
L/sec Water		0.12	0.10	0.07	0.17	0.14	0.11	0.24	0.20	0.15	0.27	0.22	0.19
DP PSI		2.2	1.6	0.9	4.6	3.2	2.0	3.5	2.5	1.5	5.2	3.6	2.6
DP K Pa		15.4	11.2	6.35	31.4	22.2	14.1	23.9	17	10.5	35.7	24.9	18.2

Note: Table intended for quick selection, for other conditions use selection software.

Performance Data

42TW – 4 ROW – 4 PIPE – Cooling - (Cont.)

Rating: 0 Pa External Static Pressure	Fan Speed	42TW4 - 08			42TW4 - 10			42TW4 - 11			42TW4 - 14		
		High	Med.	Low	High	Med.	Low	High	Med.	Low	High	Med.	Low
Capacity (KW)		8.90	7.89	7.08	11.2	10.0	8.59	14.1	12.3	11.7	15.9	14.3	12.9
Capacity (KBtu/Hr)		30.37	26.92	24.16	38.21	34.12	29.31	48.11	41.97	39.92	54.25	48.79	44.01
CFM		795	680	593	1065	897	735	1247	1055	988	1416	1247	1094
L/sec Air		375	321	280	502	423	347	589	498	466	668	588	516
SHR(Sensible/Total)		71%	70%	70%	72%	71%	70%	70%	70%	69%	70%	71%	70%
Air DB Ent		26.7	26.7	26.7	26.7	26.7	26.7	26.7	26.7	26.7	26.7	26.7	26.7
Air WB Ent		19.4	19.4	19.4	19.4	19.4	19.4	19.4	19.4	19.4	19.4	19.4	19.4
Air DB Lvng.		12.8	12.4	12.1	13.4	12.8	12.4	12.8	12.4	12.3	12.8	12.5	12.3
Air WB Lvng.		12.5	12.2	12.0	13.1	12.6	12.3	12.5	12.2	12.1	12.6	12.3	12.2
N Circuits		4	4	4	4	4	4	6	6	6	6	6	6
Face Tubes		10	10	10	10	10	10	14	14	14	14	14	14
Water In C		6.7	6.7	6.7	6.7	6.7	6.7	6.7	6.7	6.7	6.7	6.7	6.7
Water Lvng C		12.7	12.7	12.7	12.7	12.7	12.7	12.7	12.7	12.7	12.7	12.7	12.7
Gal/Min		5.62	4.98	4.46	7.09	6.34	5.42	8.86	7.77	7.37	10.00	9.04	8.13
L/sec Water		0.35	0.31	0.28	0.45	0.40	0.34	0.56	0.49	0.47	0.63	0.57	0.51
DP PSI		4.6	3.8	3.1	3.8	3.1	2.4	4.7	3.7	3.4	4.5	3.7	3.1
DP K Pa		32	25.9	21.4	26.2	21.6	16.4	32.4	25.8	23.5	30.7	25.7	21.4

25 Pa. External Static Pressure	Fan Speed	42TW4 - 08			42TW4 - 10			42TW4 - 11			42TW4 - 14		
		High	Med.	Low	High	Med.	Low	High	Med.	Low	High	Med.	Low
Capacity (KW)		8.33	7.01	6.11	10.4	8.66	7.48	13.5	11.5	10.2	15.2	13.0	11.2
Capacity (KBtu/Hr)		28.42	23.92	20.85	35.48	29.55	25.52	46.06	39.24	34.8	51.86	44.36	38.21
CFM		725	581	489	948	732	612	1179	965	822	1336	1089	915
L/sec Air		342	274	231	447	346	289	556	455	388	631	514	432
SHR		70%	69%	69%	71%	70%	69%	70%	69%	68%	70%	69%	69%
Air DB Ent		26.7	26.7	26.7	26.7	26.7	26.7	26.7	26.7	26.7	26.7	26.7	26.7
Air WB Ent		19.4	19.4	19.4	19.4	19.4	19.4	19.4	19.4	19.4	19.4	19.4	19.4
Air DB Lvng.		12.5	12.0	11.7	13.0	12.3	11.9	12.6	12.2	11.8	12.7	12.2	11.8
Air WB Lvng.		12.3	11.9	11.6	12.7	12.1	11.8	12.4	12.0	11.7	12.4	12.0	11.7
Water In C		6.7	6.7	6.7	6.7	6.7	6.7	6.7	6.7	6.7	6.7	6.7	6.7
Water Lvng C		12.7	12.7	12.7	12.7	12.7	12.7	12.7	12.7	12.7	12.7	12.7	12.7
Gal/Min		5.26	4.42	3.85	6.58	5.46	4.72	8.52	7.26	6.41	9.59	8.18	7.10
L/sec Water		0.33	0.28	0.24	0.42	0.34	0.30	0.54	0.46	0.40	0.61	0.52	0.45
DP PSI		4.1	3.1	2.4	3.3	2.4	1.9	4.4	3.3	2.7	4.1	3.1	2.5
DP K Pa		28.5	21.1	16.6	23.1	16.7	12.9	30.2	22.9	18.5	28.5	21.6	16.9

50 Pa. External Static Pressure	Fan Speed	42TW4 - 08			42TW4 - 10			42TW4 - 11			42TW4 - 14		
		High	Med.	Low	High	Med.	Low	High	Med.	Low	High	Med.	Low
Capacity (KW)		7.46	6.04	4.71	9.20	7.44	5.65	12.1	9.90	7.39	13.5	10.9	9.13
Capacity (KBtu/Hr)		25.45	20.61	16.07	31.39	25.39	19.28	41.29	33.78	25.21	46.06	37.19	31.15
CFM		626	479	354	795	599	430	1018	791	551	1141	872	702
L/sec Air		295	226	167	375	282	203	480	373	260	538	411	331
SHR		70%	68%	67%	70%	69%	67%	69%	68%	67%	70%	69%	68%
Air DB Ent		26.7	26.7	26.7	26.7	26.7	26.7	26.7	26.7	26.7	26.7	26.7	26.7
Air WB Ent		19.4	19.4	19.4	19.4	19.4	19.4	19.4	19.4	19.4	19.4	19.4	19.4
Air DB Lvng.		12.1	11.6	11.0	12.5	11.8	11.1	12.2	11.7	10.9	12.2	11.6	11.2
Air WB Lvng.		11.9	11.4	10.9	12.3	11.6	11.0	12.0	11.5	10.8	12.0	11.5	11.1
Water In C		6.7	6.7	6.7	6.7	6.7	6.7	6.7	6.7	6.7	6.7	6.7	6.7
Water Lvng C		12.7	12.7	12.7	12.7	12.7	12.7	12.7	12.7	12.7	12.7	12.7	12.7
Gal/Min		4.71	3.80	2.97	5.80	4.69	3.57	7.64	6.24	4.66	8.54	6.89	5.76
L/sec Water		0.30	0.24	0.19	0.37	0.30	0.23	0.48	0.39	0.29	0.54	0.44	0.36
DP PSI		3.4	2.4	1.5	2.7	1.9	1.2	3.6	2.6	1.6	3.4	2.3	1.7
DP K Pa		23.5	16.3	10.6	18.5	12.8	8.0	25.0	17.6	10.7	23.3	16.1	11.8

Note: Table intended for quick selection, for other conditions use selection software.

Performance Data

42TW – 4 ROW – 4 PIPE - Heating

Rating: 0 Pa External Static Pressure	Fan Speed	42TW4 - 03			42TW4 - 04			42TW4 - 05			42TW4 - 06		
		High	Med.	Low	High	Med.	Low	High	Med.	Low	High	Med.	Low
Capacity (KW)		2.94	2.73	2.60	5.47	5.32	4.87	6.78	6.16	5.90	7.85	7.41	6.89
Capacity (KBtu/Hr)		10.03	9.31	8.87	18.66	18.15	16.62	23.13	21.02	20.13	26.78	25.28	23.51
CFM		313	273	247	533	450	368	623	527	494	702	623	548
L/sec Air		148	129	116	251	212	174	294	249	233	331	294	259
Air DB Ent		20	20	20	20	20	20	20	20	20	20	20	20
Air DB Lvng.		36.4	37.5	38.4	37.9	40.7	43.1	39.0	40.4	40.8	39.5	40.8	42.0
N Circuits		2	2	2	2	2	2	2	2	2	2	2	2
Face Tubes		10	10	10	10	10	10	10	10	10	10	10	10
Water In C		70	70	70	70	70	70	70	70	70	70	70	70
Water Lvng C		61.6	61.6	61.6	61.6	61.6	61.6	61.6	61.6	61.6	61.6	61.6	61.6
Gal/Min		1.93	1.75	1.64	2.73	2.45	2.25	3.18	2.87	2.75	3.83	3.54	3.25
L/sec Water		0.12	0.11	0.10	0.17	0.15	0.14	0.20	0.18	0.17	0.24	0.22	0.21
DP PSI		4.2	3.5	3.1	7.8	6.4	5.5	2.0	1.7	1.6	3.3	2.9	2.5
DP K Pa		28.8	24.3	21.5	53.5	44.3	37.8	13.9	11.5	10.7	22.7	19.7	16.9

25 Pa. External Static Pressure	Fan Speed	High Med. Low			High Med. Low			High Med. Low			High Med. Low		
		High	Med.	Low	High	Med.	Low	High	Med.	Low	High	Med.	Low
Capacity (KW)		2.83	2.52	2.29	5.09	4.65	4.29	6.54	5.81	5.22	7.64	6.77	6.09
Capacity (KBtu/Hr)		9.66	8.60	7.81	17.37	15.87	14.64	22.31	19.82	17.81	26.07	23.10	20.78
CFM		295	242	206	474	366	305	589	483	411	673	545	457
L/sec Air		139	114	97	224	173	144	278	228	194	318	257	216
Air DB Ent		20	20	20	20	20	20	20	20	20	20	20	20
Air DB Lvng.		36.7	38.2	39.4	38.8	42.2	44.5	39.4	41.0	42.2	39.8	41.7	43.3
Water In C		70	70	70	70	70	70	70	70	70	70	70	70
Water Lvng C		61.6	61.6	61.6	61.6	61.6	61.6	61.6	61.6	61.6	61.6	61.6	61.6
Gal/Min		1.85	1.61	1.44	2.53	2.14	1.98	3.07	2.70	2.43	3.73	3.24	2.88
L/sec Water		0.12	0.10	0.09	0.16	0.14	0.12	0.19	0.17	0.15	0.24	0.20	0.18
DP PSI		3.9	3.0	2.5	6.8	5.1	4.4	1.9	1.5	1.2	3.1	2.4	2.0
DP K Pa		26.9	21	17.1	46.9	34.9	30.1	13	10.4	8.56	21.6	16.8	13.6

50 Pa. External Static Pressure	Fan Speed	High Med. Low			High Med. Low			High Med. Low			High Med. Low		
		High	Med.	Low	High	Med.	Low	High	Med.	Low	High	Med.	Low
Capacity (KW)		2.55	2.18	1.71	4.54	4.06	3.35	5.95	5.08	3.96	6.84	5.81	5.05
Capacity (KBtu/Hr)		8.70	7.44	5.83	15.49	13.85	11.43	20.30	17.33	13.51	23.34	19.82	17.23
CFM		255	198	138	397	300	215	509	396	276	570	436	351
L/sec Air		120	93	65	187	141	102	240	187	130	269	206	166
Air DB Ent		20	20	20	20	20	20	20	20	20	20	20	20
Air DB Lvng.		37.5	39.2	41.6	40.0	43.7	47.2	40.4	42.4	45.1	40.9	43.3	45.1
Water In C		70	70	70	70	70	70	70	70	70	70	70	70
Water Lvng C		61.6	61.6	61.6	61.6	61.6	61.6	61.6	61.6	61.6	61.6	61.6	61.6
Gal/Min		1.67	1.40	1.07	2.26	1.87	1.55	2.80	2.36	1.84	3.34	2.78	2.39
L/sec Water		0.11	0.09	0.07	0.14	0.12	0.10	0.18	0.15	0.12	0.21	0.18	0.15
DP PSI		3.2	2.3	1.5	5.6	4.0	2.8	1.6	1.2	0.8	2.6	1.9	1.4
DP K Pa		22.4	16.2	10.2	38.4	27.4	19.4	11	8.18	5.26	17.8	12.8	9.78

Note: Table intended for quick selection, for other conditions use selection software.

Performance Data

42TW – 4 ROW – 4 PIPE – Heating (Cont.)

Rating: 0 Pa External Static Pressure	Fan Speed	42TW4 - 08			42TW4-10			42TW4 - 11			42TW4 - 14		
		High	Med.	Low	High	Med.	Low	High	Med.	Low	High	Med.	Low
Capacity (KW)	9.39	8.78	7.98	12.2	11.4	10.2	13.9	12.7	12.2	17.5	16.3	15.1	
Capacity (KBtu/Hr)	32.04	29.96	27.23	41.63	38.90	34.80	47.43	43.33	41.63	59.71	55.62	51.52	
CFM	795	680	593	1065	897	735	1247	1055	988	1416	1247	1094	
L/sec Air	375	321	280	502	423	347	589	498	466	668	588	516	
Air DB Ent	20	20	20	20	20	20	20	20	20	20	20	20	
Air DB Lvng.	40.6	42.5	43.5	40.0	42.2	44.2	39.5	41.0	41.6	41.6	42.8	44.1	
N Circuits	2	2	2	2	2	2	3	3	3	3	3	3	
Face Tubes	10	10	10	10	10	10	14	14	14	14	14	14	
Water In C	70	70	70	70	70	70	70	70	70	70	70	70	
Water Lvng C	61.6	61.6	61.6	61.6	61.6	61.6	61.6	61.6	61.6	61.6	61.6	61.6	
Gal/Min	4.51	4.07	3.70	5.61	5.25	4.68	6.76	6.06	5.80	8.05	7.52	6.97	
L/sec Water	0.28	0.26	0.23	0.35	0.33	0.30	0.43	0.38	0.37	0.51	0.47	0.44	
DP PSI	4.8	4.0	3.4	7.1	6.3	5.1	4.7	3.8	3.6	7.0	6.2	5.4	
DP K Pa	33	27.5	23.2	48.7	43.3	35.2	32.1	26.5	24.5	48.4	42.8	37.5	

25 Pa. External Static Pressure	Fan Speed	High	Med.	Low	High	Med.	Low	High	Med.	Low	High	Med.	Low
		Capacity (KW)	8.83	7.88	6.98	11.3	9.96	8.94	13.5	11.9	10.7	16.8	14.9
Capacity (KBtu/Hr)	30.13	26.89	23.82	38.56	33.98	30.50	46.06	40.60	36.51	57.32	50.84	45.72	
CFM	725	581	489	948	732	612	1179	965	822	1336	1089	915	
L/sec Air	342	274	231	447	346	289	556	455	388	631	514	432	
Air DB Ent	20	20	20	20	20	20	20	20	20	20	20	20	
Air DB Lvng.	41.3	43.7	44.9	40.8	43.8	45.5	40.0	41.5	42.7	42.0	43.9	45.6	
Water In C	70	70	70	70	70	70	70	70	70	70	70	70	
Water Lvng C	61.6	61.6	61.6	61.6	61.6	61.6	61.6	61.6	61.6	61.6	61.6	61.6	
Gal/Min	4.24	3.65	3.24	5.21	4.59	4.12	6.53	5.71	5.12	7.75	6.86	6.16	
L/sec Water	0.27	0.23	0.20	0.33	0.29	0.26	0.41	0.36	0.32	0.49	0.43	0.39	
DP PSI	4.3	3.3	2.7	6.2	4.9	4.1	4.4	3.5	2.8	6.6	5.3	4.4	
DP K Pa	29.6	22.7	18.3	42.7	34.1	28.1	30.2	23.8	19.6	45.2	36.4	30.1	

50 Pa. External Static Pressure	Fan Speed	High	Med.	Low	High	Med.	Low	High	Med.	Low	High	Med.	Low
		Capacity (KW)	7.99	6.89	5.54	10.1	8.67	6.94	12.2	10.4	8.11	15.1	12.7
Capacity (KBtu/Hr)	27.26	23.51	18.90	34.46	29.58	23.68	41.63	35.48	27.67	51.52	43.33	37.53	
CFM	626	479	354	795	599	430	1018	791	551	1141	872	702	
L/sec Air	295	226	167	375	282	203	480	373	260	538	411	331	
Air DB Ent	20	20	20	20	20	20	20	20	20	20	20	20	
Air DB Lvng.	42.3	45.1	47.3	42.2	45.3	48.2	40.9	43.0	45.7	43.1	45.4	47.4	
Water In C	70	70	70	70	70	70	70	70	70	70	70	70	
Water Lvng C	61.6	61.6	61.6	61.6	61.6	61.6	61.6	61.6	61.6	61.6	61.6	61.6	
Gal/Min	3.84	3.19	2.57	4.65	3.99	3.20	5.92	4.99	3.87	6.97	5.87	5.09	
L/sec Water	0.24	0.20	0.16	0.29	0.25	0.20	0.37	0.31	0.24	0.44	0.37	0.32	
DP PSI	3.6	2.6	1.8	5.1	3.9	2.6	3.7	2.7	1.7	5.4	4.0	3.1	
DP K Pa	24.8	17.8	12.2	34.9	26.6	17.9	25.4	18.7	11.9	37.4	27.6	21.4	

Note: Table intended for quick selection, for other conditions use selection software.

Performance Data

Fan Performance – ENGLISH

42TW3 Air Flow (CFM)												
Ex. Static Pres. in wg	0			0.05			0.1			0.15		
Unit Size	H	M	L	H	M	L	H	M	L	H	M	L
03	348	303	274	334	283	249	320	263	224	295	237	185
05	592	498	408	553	448	370	515	398	332	467	353	278
06	692	586	548	666	555	497	640	524	447	603	466	373
07	780	691	607	756	642	552	732	592	497	682	527	443
09	883	756	659	836	693	595	789	630	531	724	570	457
11	1181	995	815	1106	895	740	1031	796	665	935	706	557
12	1385	1172	1096	1333	1110	995	1281	1048	893	1205	931	746
16	1572	1383	1214	1512	1283	1104	1452	1184	995	1363	1054	885

42TW3 Air Flow (CFM)									
Ex. Static Pres. in wg	0.2			0.25			0.3		
Unit Size	H	M	L	H	M	L	H	M	L
03	271	211	147	224	159	–	180	–	–
05	423	318	229	368	258	–	308	–	–
06	541	421	294	434	318	–	329	–	–
07	607	464	373	524	383	–	453	–	–
09	659	509	383	589	436	–	507	–	–
11	846	637	457	736	517	–	617	–	–
12	1082	842	587	846	621	–	642	–	–
16	1214	927	746	1042	762	–	901	–	–

H – At High Fan Speed.
M – At Medium Fan Speed.
L – At Low Fan Speed.

Fan Performance – ENGLISH

42TW4 Air Flow (CFM)												
Ex. Static Pres. in wg	0			0.05			0.1			0.15		
Unit Size	H	M	L	H	M	L	H	M	L	H	M	L
03	313	273	247	304	257	225	295	242	206	275	220	172
05	533	450	368	503	408	337	474	366	305	434	328	259
06	623	527	494	606	505	453	589	483	411	560	433	347
07	702	623	548	687	584	503	673	545	457	634	490	411
09	795	680	593	760	631	541	725	581	489	676	530	422
10	1065	897	735	1006	815	673	948	732	612	870	657	518
11	1247	1055	988	1213	1010	905	1179	965	822	1121	866	694
14	1416	1247	1094	1376	1168	1005	1336	1089	915	1267	981	823

42TW4 Air Flow (CFM)									
Ex. Static Pres. In wg	0.2			0.25			0.3		
Unit Size	H	M	L	H	M	L	H	M	L
03	255	198	138	214	164	–	174	–	–
05	397	300	215	350	245	–	296	–	–
06	509	396	276	412	303	–	316	–	–
07	570	436	351	498	364	–	434	–	–
09	626	479	354	559	421	–	486	–	–
10	795	599	430	699	491	–	592	–	–
11	1018	791	551	803	590	–	616	–	–
14	1141	872	702	990	724	–	865	–	–

H – At High Fan Speed.
M – At Medium Fan Speed.
L – At Low Fan Speed.

Performance Data

Fan Performance – SI

42TW3 Air Flow (m ³ /hr)												
Ex. Static Pres. Pa	0			12.5			25			37.5		
Unit Size	H	M	L	H	M	L	H	M	L	H	M	L
03	592	515	466	568	481	423	544	446	380	502	402	315
05	1005	846	694	940	761	629	875	676	564	794	600	473
06	1176	995	931	1132	943	845	1088	891	759	1024	791	634
07	1325	1174	1031	1284	1090	938	1243	1006	845	1158	896	752
09	1500	1285	1120	1420	1178	1011	1340	1071	902	1230	968	776
11	2007	1690	1385	1879	1521	1257	1751	1352	1129	1589	1200	946
12	2353	1991	1862	2265	1886	1690	2177	1781	1518	2048	1582	1268
16	2671	2349	2062	2569	2180	1876	2467	2011	1690	2315	1791	1504

42TW3 Air Flow (m ³ /hr)									
Ex. Static Pres. Pa	50			62.5			75		
Unit Size	H	M	L	H	M	L	H	M	L
03	460	358	250	380	270	–	305	–	–
05	718	541	389	625	439	–	524	–	–
06	919	715	499	737	541	–	559	–	–
07	1031	788	634	890	651	–	769	–	–
09	1120	865	650	1000	740	–	862	–	–
11	1437	1082	777	1251	879	–	1048	–	–
12	1839	1430	997	1437	1055	–	1091	–	–
16	2062	1575	1268	1770	1295	–	1530	–	–

H – At High Fan Speed.
M – At Medium Fan Speed.
L – At Low Fan Speed.

Fan Performance – SI

42TW4 Air Flow (m ³ /hr)												
Ex. Static Pres. Pa	0			12.5			25			37.5		
Unit Size	H	M	L	H	M	L	H	M	L	H	M	L
03	532	463	419	517	437	383	502	411	350	467	373	292
05	905	764	625	855	693	572	805	622	519	738	558	440
06	1059	896	840	1030	858	769	1001	820	698	952	736	590
07	1192	1058	931	1168	992	854	1144	926	777	1077	833	699
09	1350	1156	1007	1291	1072	919	1232	987	831	1148	900	717
10	1809	1524	1249	1710	1384	1144	1611	1244	1039	1478	1116	880
11	2119	1793	1679	2061	1716	1538	2003	1639	1397	1905	1471	1179
14	2406	2118	1859	2338	1984	1707	2270	1850	1555	2153	1666	1399

42TW4 Air Flow (m ³ /hr)									
Ex. Static Pres. Pa	50			62.5			75		
Unit Size	H	M	L	H	M	L	H	M	L
03	433	336	235	363	279	–	296	–	–
05	675	509	366	594	417	–	503	–	–
06	864	672	469	700	514	–	537	–	–
07	969	741	596	846	618	–	738	–	–
09	1063	813	602	950	715	–	825	–	–
10	1351	1017	730	1188	835	–	1006	–	–
11	1729	1344	937	1365	1002	–	1047	–	–
14	1938	1481	1192	1682	1230	–	1469	–	–

H – At High Fan Speed.
M – At Medium Fan Speed.
L – At Low Fan Speed.

Sound Data

SOUND PRESSURE – 42TW 3ROW

External static Pressure	@ 0 Pa ESP			@ 25 Pa ESP			@ 50 Pa ESP		
	Hi	Med	Low	Hi	Med	Low	Hi	Med	Low
Motor Speed									
42TW3-03	47.5	45.5	43.5	46.5	44.0	42.5	45.5	42.5	41.0
42TW3-05	48.5	46.5	44.5	47.5	45.0	43.5	46.5	43.5	42.0
42TW3-06	50.0	48.0	46.0	49.0	46.5	45.0	48.0	45.0	43.5
42TW3-07	50.5	48.5	46.5	49.5	47.0	45.5	48.5	45.5	44.0
42TW3-09	50.0	48.0	46.0	49.5	47.0	45.5	48.5	45.5	43.5
42TW3-11	51.0	49.0	47.0	50.0	47.5	46.0	49.0	46.0	44.0
42TW3-12	51.0	49.0	47.0	50.0	47.5	46.0	49.0	46.0	44.5
42TW3-16	51.5	49.5	47.5	50.5	48.0	46.5	49.5	46.5	45.0

SOUND PRESSURE – 42TW 4ROW

External static Pressure	@ 0 Pa ESP			@ 25 Pa ESP			@ 50 Pa ESP		
	Hi	Med	Low	Hi	Med	Low	Hi	Med	Low
Motor Speed									
42TW4-03	46.5	44.5	42.5	46.0	43.5	42.0	45.0	42.0	40.5
42TW4-04	47.5	45.5	43.5	47.0	44.5	43.0	46.0	43.0	41.5
42TW4-05	49.0	47.0	45.0	48.5	46.0	44.5	47.5	44.5	43.0
42TW4-06	49.5	47.5	45.5	49.0	46.5	45.0	48.0	45.0	43.5
42TW4-08	49.0	47.0	45.0	49.0	46.5	45.0	48.0	45.0	43.0
42TW4-10	50.0	48.0	46.0	49.5	47.0	45.5	48.5	45.5	43.5
42TW4-11	50.0	48.0	46.0	49.5	47.0	45.5	48.5	45.5	44.0
42TW4-14	50.5	48.5	46.5	50.0	47.5	46.0	49.0	46.0	44.5

Note: Assumes "standard room ", 3 meters from exit, no ducts, ducts will further reduce sound

Application Data

SELECTION PROCEDURE:

Tables in this publication are meant for quick selection (+/- 10%). For specific conditions user can use selection software available from Carrier dealer or seek application support from Carrier sales engineer.

QUICK SELECTION:

EXAMPLE:

Customer requires fan coil having following performance:

1. CFM= 700 +/-5%, at 0.1 InH2O (25 Pa) pressure.
2. Cooling Capacity= 24,000 Btu/Hr
3. Entering Air= 24 DB, 18 WB
4. Water in = 6.7 C

STEP 1:

From fan performance table (page 16&17) at 0.1 In H2O we find that FCU 42TW3-07-2 will deliver 732 CFM at 0.1 In H2O & high speed.

STEP 2:

From 42TW3 capacity tables (page 8&9) we find the following performance at 26.7/19 DB/WB:

Unit 42TW	Performance @26.7/19	Correction @24/18	Performance @24/18
Capacity	29,070	-12%	25,581
CFM	732	***	***
SHR	0.71	-1%	0.7
Air In	26.7/19	***	24/18
Air Out	12.3/11.9	-0.7	11.6/11.3
Water In	6.7	***	***
Water Out	12.7	-0.7	12
Gal/Min	5.38	***	5.38
DP PSI	8.8	***	8.8

Note that tables yield performance within 5-10% of most requirements.

SELECTION SOFTWARE:

For specific conditions user can use selection software available from Carrier dealer or ask for technical support from Carrier sales engineer.

ALTITUDE CORRECTION:

Altitude correction on performance is -1% for every 1000 ft above sea level.

Application Data – (Cont.)

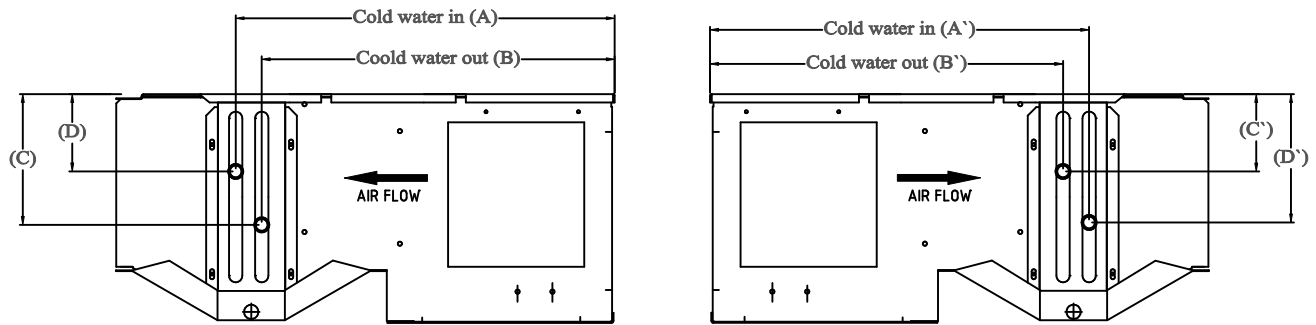

Right Hand Connection (Standard)

Left hand Connection (Option)

All dimensions in cm	Right Hand Connection (Standard)				Left Hand Connection (Option)			
	A	B	C	D	A'	B'	C'	D'
42 TW 3 Rows 2 pipes	45.5	41	18.5	11	45.5	41	8	15.5
42TW3-03								
42TW3-05								
42TW3-06								
42TW3-07			23.5	16			13	20.5
42TW3-09								
42TW3-11								
42TW3-12								
42TW3-16								

All dimensions in cm	Right Hand Connection (Standard)				Left Hand Connection (Option)			
	A	B	C	D	A'	B'	C'	D'
42 TW 4 Rows 2 pipes	46	40	18.5	11	46	40	8	15.5
42TW4-03								
42TW4-04								
42TW4-05								
42TW4-06			23.5	16			13	20.5
42TW4-08								
42TW4-10								
42TW4-11								
42TW4-14								

Typical Wiring Schematic

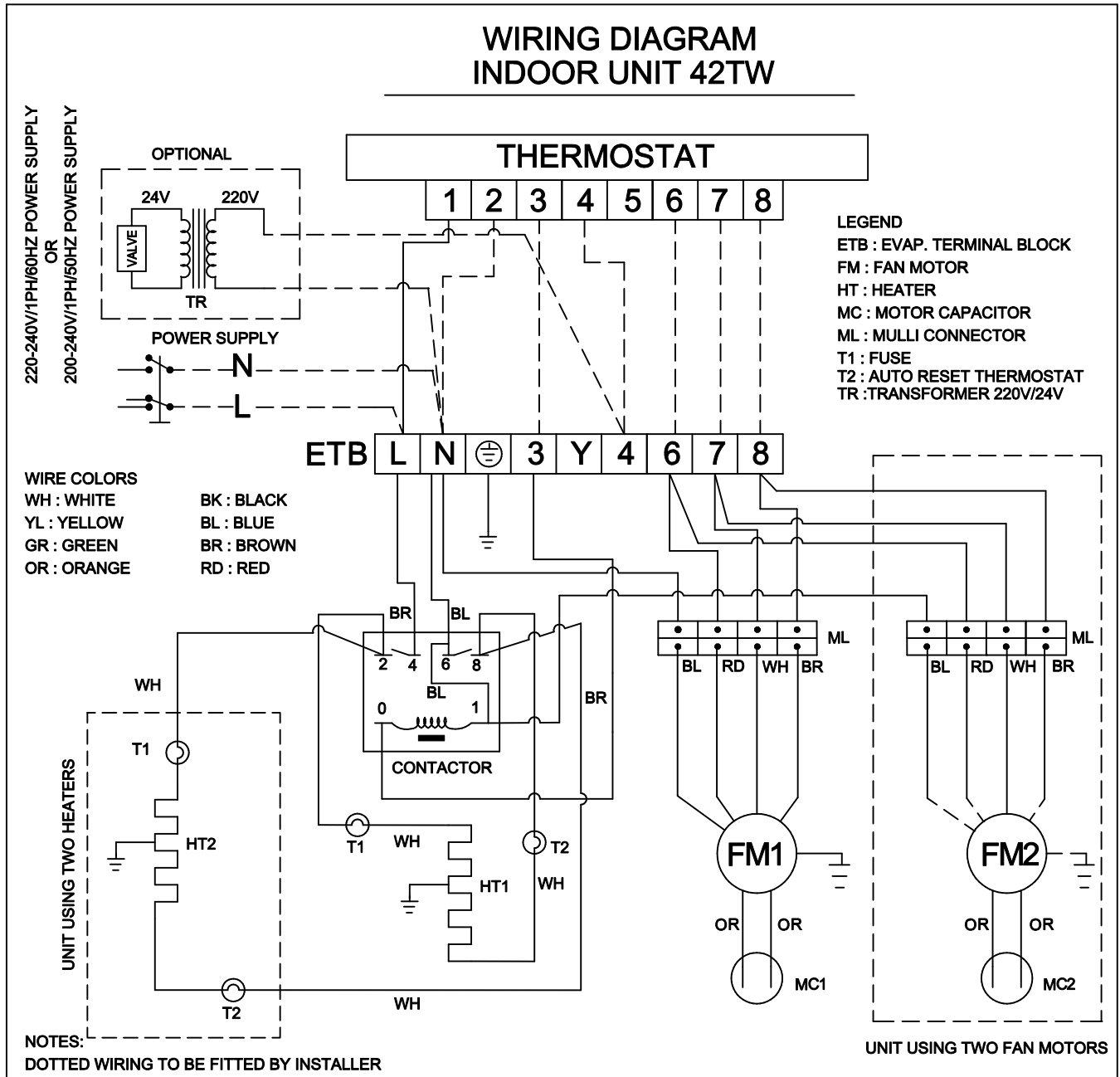

Note: The fan coil unit should be wired to the thermostat 220 v, which is field supplied option as shown in the wiring diagram.

Options & Accessories

ELECTRIC HEATER OPTION

A single heater element having capacity of 1.5, 2.0 and 2.5 kw or two heater elements with a combined capacity of 3.0, 4.0 and 5.0 KW can be factory installed (Option), the electric heater is open type with thermal protection and fuse for more safety. In case of electric heaters a special quiet contactor is installed in the electric box to minimize contactor noise when heater is energized and de-energized. Normal heater capacity and high heater capacity option are available as shown in the following table:

42TW 3 Rows Models	42TW 4 Rows Models	Normal Heater option, watts	High Heater option, watts
42TW3-03	42TW4-03	1500	2000
42TW3-05	42TW4-04	1500	2000
42TW3-06	42TW4-05	1500	2000
42TW3-07	42TW4-06	2000	2500
42TW3-09	42TW4-08	2500	3000
42TW3-11	42TW4-10	3000	4000
42TW3-12	42TW4-11	4000	5000
42TW3-16	42TW4-14	4000	5000

CONNECTION SIDE OPTION

Standard coil connection and electric box position is RH facing air flow direction while the optional position is LH facing the air flow for both coil connection and electric box.

Customers can order this option directly from the factory also units are designed to be field exchangeable if needed in the field.

TRANSFORMER OPTION

A 24 v transformer can be optionally installed as shown in the wiring diagram to operate the valve package.

THERMOSTAT OPTION

A three speed cool/electric heat thermostat 220 v (Model # 25-074-31) is field supplied option with the unit; other thermostats may also be used.

Optional 220v thermostat has the following features:

- Attractive plastic molded casing.
- Dial temperature setting with stop at 18 C for economic operation.
- 3 Speed selection switch can be set to low speed for extra quiet night time operation.

Guide Specification

Carrier 42TW

GENERAL

SYSTEM DESCRIPTION

The fan coil unit is designed for under ceiling installation, electrically controlled cooling and heating (option). Unit shall be designed horizontal installation. Standard unit shall include washable permanent aluminum filter. Unit shall be designed for medium external static pressure up to 0.25 inch water.

QUALITY ASSURANCE

A- Unit shall be rated in accordance with ARI standard.

B- Unit shall be manufactured in facility registered to ISO9001: 2000 standard.

PRODUCT

A- The unit shall be factory assembled single piece cooling unit, with optional electric heat in case of 2 pipe system.

B- Unit cabinet shall be constructed of galvanized steel. The unit shall be insulated with polyester urethane insulation that is 1/2 inch thickness & 24 kg/m³ density, Unit cabinet panels shall be single skin

C- Unit shall have a permanent washable aluminum filter. Filter shall be flame retardant and easy accessible through an access panel.

D- Units shall have V shape external drain pan with 1/2 inch insulation, the drain pane shall be galvanized steel coated with polyester powder for extra protection.

E- The unit fan wheel shall be directly connected to the motor. The fan wheel shall be made from ABS, it shall be a dynamically balanced with double inlet forward curved type blower wheel.

F- Unit coil shall have aluminum fins mechanically bonded to seamless smooth copper tubes 3/8 inch with all joints brazed. Unit coil shall be accessible for cleaning.

G- The coil connection shall be sweat type, it shall be RH/LH exchangeable.

H- The unit fan motor shall have permanently lubricated sleeve bearing and 3 speeds, the motor shall have overload protection and B class insulation.

I- All electric parts shall be easy accessible for service.

G- Unit control board shall be 220 V.

K- Optional 24 v transformer can be ordered for valve operation.



Turn to the Experts™

Manufacturer reserves the right to discontinue, or change at any time, specifications or designs without notice and without incurring obligations

Jan 2008

42TW-04 PD