

**39FX  
Central Station  
Air Handling Units  
1000 m<sup>3</sup>/hr to 160,000 m<sup>3</sup>/hr Nominal Air Flow**



Turn to the Experts.™

## Product Data

39FX Series Central Station Air Handling Units are designed based on Carrier 'Moduflex' Series. The design of the Central Station Air Handling Units is based on the use of standardized modular panels and 'penta-post' construction of perimeter frames. The standard and reference for design and performances for 39FX Central Station AHUs components shall conform accordance to EUROVENT, DIN, ASHRAE, AMCA, UL and ARI Standard. Standard units configuration shall be horizontal or vertical draw-through or blow-through types.

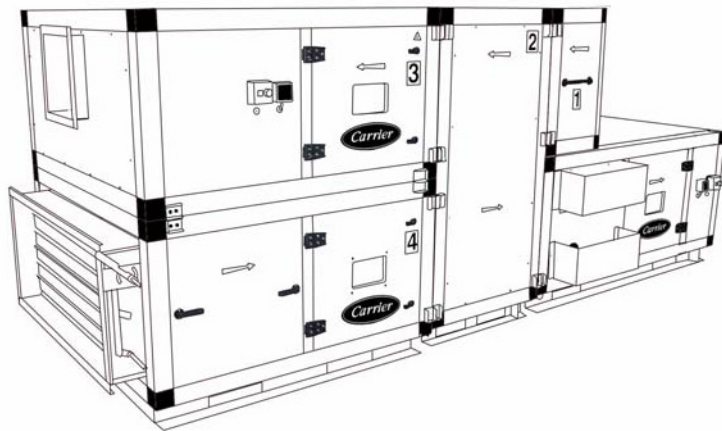

### Features/Benefits

- Flexible modular construction with 29 different sizes offers several configurations of unit height and width to meet installation space requirements.
- Units are offered with double skin panels 50mm thickness.
- Designed as per EN1886, fabricated from heavy gauge galvanized powder painted steel sheet with linear gasket between panels to ensure sturdy construction and excellent leak tight.
- Excellent Casing Performance:
  - Casing Strength Class D1(=2A).
  - Casing Leakage Class L3(=A).
  - Casing Thermal Transmittance Class T3.
  - Casing Thermal Bridging Class TB2.
  - Filter Leakage Class F7
- Fan and motor packages are mounted on common bases with vibration isolators to ensure moving parts are isolated from the casing structure.
- Manufactured at an ISO 9001 listed facility to guarantee quality.
- ARI 410 Certified coils.

## QUALITY

The quality and reliability of any system depends on the quality of the component parts. Therefore, inline with other *Carrier* products our 39F Series Air Handlers are manufactured in conformity with *Carrier's* Quality concept with vendor items subjected to rigorous inspection. Components installed in Air Handlers are manufactured, tested or rated in compliance to international standards.

## MODULAR CONSTRUCTION

This adaptable unit design which is based upon a wide range of standard panel sizes frequently enables *Carrier* to offer several configurations of unit height and width, so that the aesthetic or practical dictates of confined plant room space or rooftop silhouettes can be easily met.

Major sections of the Air Handling Unit such as fan, coil, filter, etc, can be arranged in the sequence dictated by the job requirements, and separated by access sections where necessary, giving complete flexibility of design.

## RIGID CONSTRUCTION

The *Carrier* series 39F Air Handling Unit is fabricated from heavy gauge galvanized powder painted steel sheet, which is folded to form sturdy side, top and bottom panels and a rigid "Penta Post" supporting frame.

Panels and frame are secured using internally bolted fixings so that welding is minimized and the integrity of the galvanized finish is maintained. Gasket liner between panels and frame ensures excellent leak tight and also as thermal and acoustic insulation. This bolted construction, and the use of standardized components facilitates the removal of panels for maximum access to fans, coils, filters, etc.

## WIDE RANGE OF SIZES

29 standard sizes provide air quantities from,

- 1008 m<sup>3</sup>/hr to 160,000 m<sup>3</sup>/hr – cooling duty
- 1008 m<sup>3</sup>/hr to 250,000 m<sup>3</sup>/hr – heating only duty

For duties in excess of the above, please contact your *Carrier* office.

## FLEXIBIL PANEL VARIATY

29 Different sizes offered with double skin panels, 50 mm thick polurrthane filled for excellent heat resistance.

## VIBRATION ISOLATION

Centrifugal fan/motor packages are mounted on common bases with rubber or spring vibration isolators and flexible canvas ensuring that all moving parts are

independently isolated from the casing structure.

## AESTHETICS

The standard construction features galvanized panel and frame finished in light gray polyester powder paint, capable of withstanding 1000 hours of direct salt spray confirming to ASTM B117.

## EASY ACCESS & MAINTENANCE

The easily removable panels and quick release access doors offer complete accessibility to fans, coils, filters and dampers. Additional access sections can be provided between coils and filters if required.

All component parts are standard and interchangeable. Filters are commercially available standard items conforming to international standards and sizes.

## CUSTOMIZED PRODUCT LINE

All 29 standard sizes are available as 'Customized' adapted exactly to meet specific job requirements.

For example: non-standard coil materials, variable fan speed control, humidifiers, attenuators, etc.

## Table of Contents

	Page
Features & Benefits.....	1
Model Number Nomenclature.....	3
Quick Selection .....	4-5
Components .....	6-7
Casing .....	8
Dimension.....	9
Dampers.....	10-11
Filters.....	11-14
Fans.....	15-18
Motor.....	19-20
Drives.....	21
Coils.....	22-25
Electric Heaters.....	26-27
Energy Recovering System.....	28-31
Humidifiers.....	32-34
Sound Attenuators.....	35
Application Guide.....	36-38
Appendix.....	39

## Quality Assurance



# 0410019950420

Approvals :

ISO 9001 : 2000

EN ISO 9001 : 2000

ANSI/ASQC Q9001 : 2000



# Model Number Nomenclature

The 39F line of *Carrier* Air Handling Units is based on Modular system

The number of modules respectively in height and in width determines the cross-section available for airflow and encodes the unit size.

The unit length is determined by the number and size of the component parts required.

The side for services (connections and access) is defined as right hand or left hand in the direction of the airflow.

Example: (see sketch below)

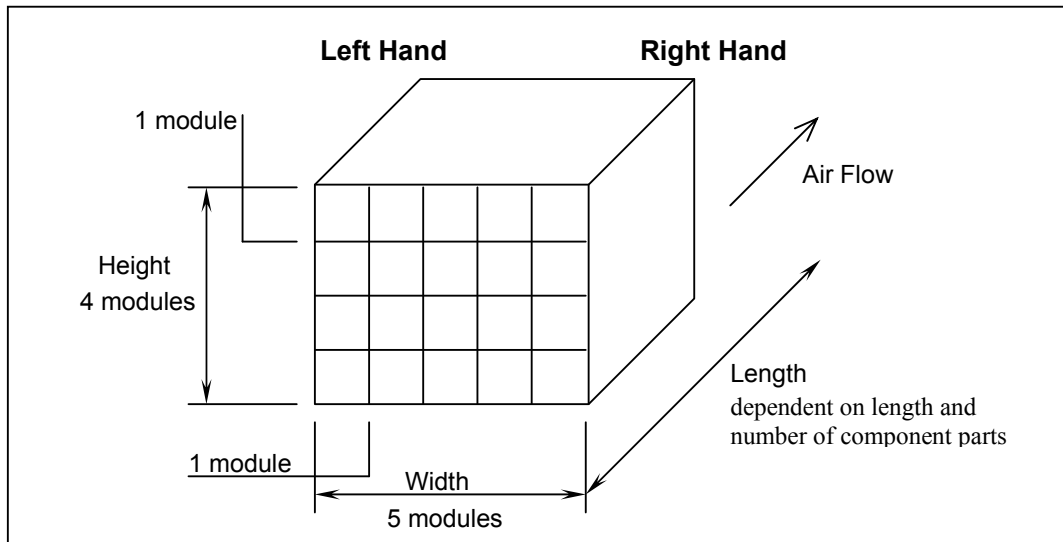
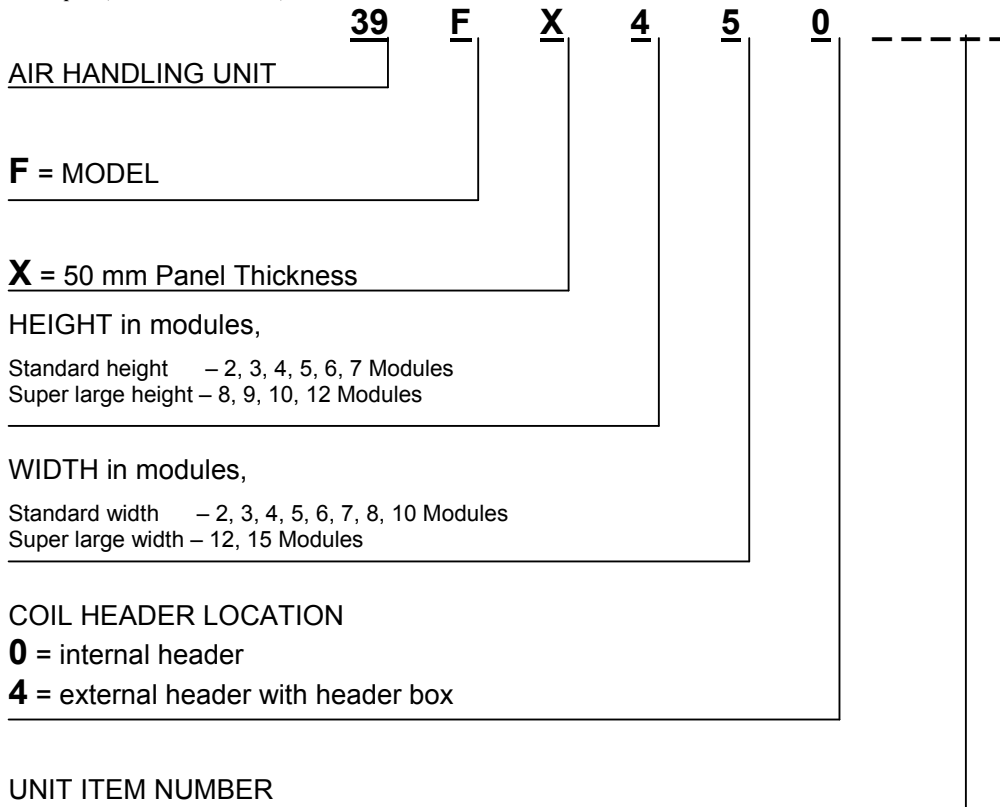

# Quick Selection

The air volume entering the finned coil section determines the unit size as follows,

1.5 m/s minimum velocity (cooling or heating)

3.15 m/s maximum velocity for cooling coil with droplet eliminator\*

2.6 m/s maximum velocity for cooling coil without droplet eliminator

4.5 m/s maximum velocity for heating coil

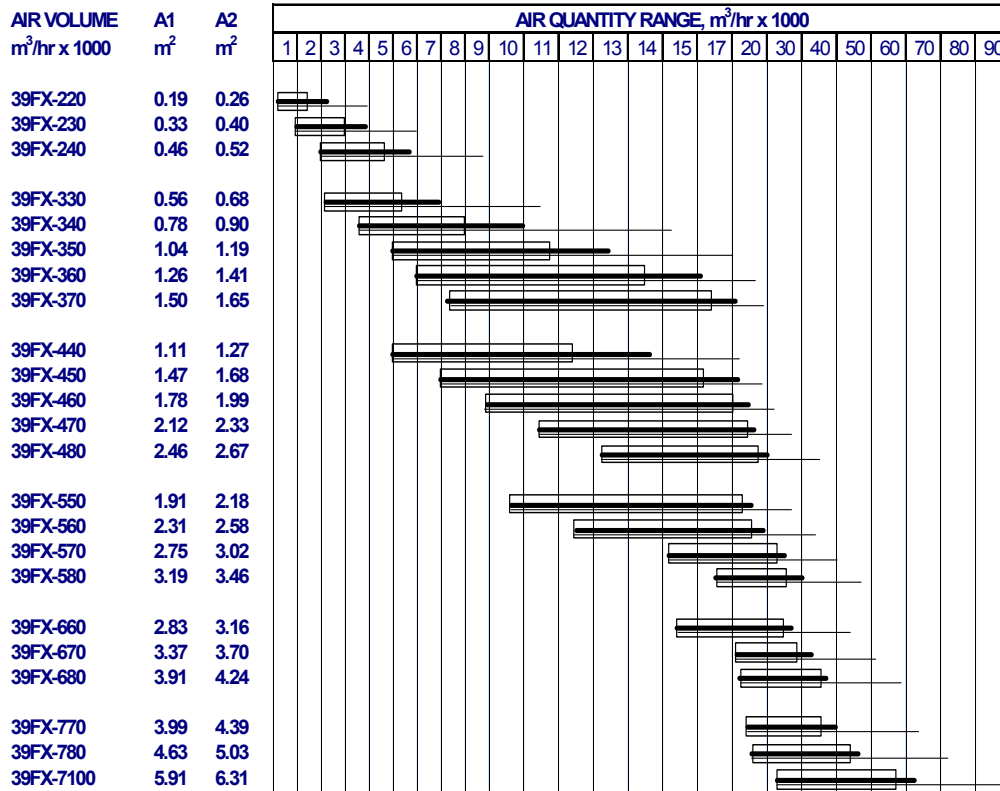



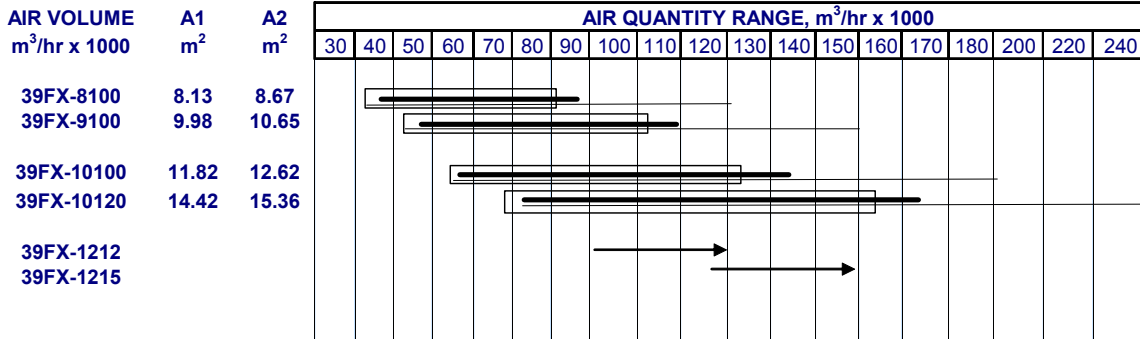

- Min. to Max Airflow for Cooling Coils (Standard Coil).
- Airflow for Cooling Coils @ Extended Coils (Enlarged Coil Face Area).
- Airflow for Heating Coils
- A1** Coil Face Area For Standard Coil (m<sup>2</sup>).
- A2** Coil Face Area For Enlarged Coil (m<sup>2</sup>), ( External Headers )

# Quick Selection

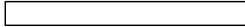
Quick selection for larger air handling unit sizes



-  Min. to Max Airflow for Cooling Coils
-  Airflow for Cooling Coils @ Extended Coils (External Headers).
-  Airflow for Heating Coils ( Standard Coil )
-  Ventilation @ 2.0 ? 2.5 m/s Face Velocity
- A1** Coil Face Area For Standard Coil (m2).
- A2** Coil Face Area For Enlarged Coil (m2), ( External Headers )

*Example:*

To determine the size of a unit delivering 30000 m<sup>3</sup>/hr of air (unit supplied with cooling and heating coil), two selections are possible,





- size 570 (standard unit) with droplet eliminator, coil section 2.75m<sup>2</sup> face area
  - size 670 (customized unit) without droplet eliminator, coil section 3.369m<sup>2</sup> face area
- $$\frac{30000}{3600 \times 2.745} = 3.04 \text{ m/s (max 3.15 m/s)}$$
- $$\frac{30000}{3600 \times 3.369} = 2.47 \text{ m/s (max 2.5m/s)}$$

\* FlexAir Program final selection for droplet eliminator depend to programmed set-up on max coil face velocity, sensible heat factor, condensate water volume and fan spacing.



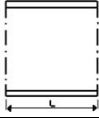

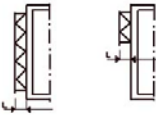
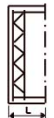
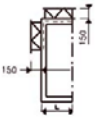
# Components

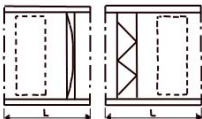
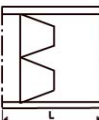
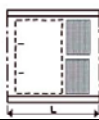
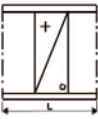
## LIST OF COMPONENTS AND THEIR CASING LENGTH

Airflow from left to right

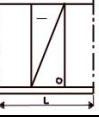
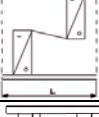
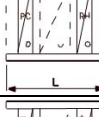
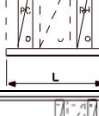
Component	Symbol	Length
Empty box		L = n x M L max = 10 M (for AHU width < 8 modules). L max = 7 M (for AHU width ≥ 8 modules).
Door		L = 580 mm combined in 2 M
Damper on outside of case : full face half face		L = 150 mm External protrusion from case
Box with one damper		L = 1 module
Mixing box with two dampers		Unit size: L = 220 to 480 2 M 550 to 680 3 M 770 to 7100 4 M
Combination mixing box with three dampers		Unit size: L = 220 to 480 4 M 550 to 680 6 M 770 to 7100 8 M
Side withdrawal filters : metallic flat synthetic flat vee filter		L = 1 M With side panel for quick access
Front or back withdrawal filters : metallic filters synthetic flat vee filter		L = 2 M with access door upstream or downstream L = 0 if filters are built into mixing box
Soft bag filter Rigid bag filter		L = 2 M with access via mix box 3 M with downstream access 4 M with upstream access
Absolute filter or carbon filter		L = 2 M with access via mix box 3 M with upstream access
Hot water coil		1 to 4 rows L = 1 M 5 to 8 rows L = 2M

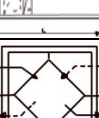
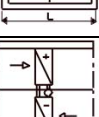
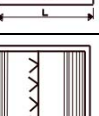
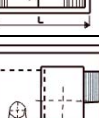
# Components

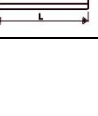
Component	Symbol	Length
Electric heating coil		L = 1 M
Cooling coil		L = 2 M
Cooling Coil for Super Large AHU		L = 5M
Run Around Coil Pre-cool & Reheat		L = 3M
Heat Pipe Pre-cool & Reheat		L = 3M
Run Around Coil for Super Large AHU Pre-cool & Reheat		L = 7M
Heat Pipe for Super Large AHU Pre-cool & Reheat		L = 7M
Plate recuperator		L = 3 to 8 M See section on heat recovery
Run around heat Recovery coils		L = 2 M 2 sections required
Humidifier 1 or 2 spray tree(s)		1 spray tree    L = 4 M 2 spray trees    L = 6 M
Supply or exhaust fan		L = See section for fans
Sound attenuator		L = 3 – 4 – 5 or 6 M See section on sound attenuator

# Casing

## GENERAL

The 39F casings come with double skin features and consist of penta post frame, fixed and removable panels, and internal insulation. The casing constructions are designed for excellent air-tightness, thermal and acoustical insulated features. The sturdy construction of panels and frames are from galvanized, minimized spangle (G90) and are aesthetically finished with 50 micron light gray powder paint. The casing or section arrangements are flexible depends on the requirements.

### Quality

39FX Casing tested by Eurovent @ TÜVSUD, EN1886.

1. Mechanical Strength Class D1.
2. Casing Air Leakage Class L3.
3. Filter By-Pass Leakage Class F7.
4. Thermal Transmittance Class T3.
5. Thermal Bridging Class TB2.

### Frame

The frame is made up of 3 components,

- penta post frame
- corner piece
- intermediate post

1. Penta post frame  
Forms the overall shape of the section and receives the panels. The penta post is manufactured from press formed, 16 gauge galvanized steel sheet, externally painted and internally insulated with Styrofoam of 32 kg/m<sup>3</sup> density.
2. Corner piece  
Completes corner section by connecting penta post in three planes. Manufactured from glass fiber reinforced polyamide.
3. Intermediate post  
Recessed to accept panels and stiffens the case assembly. Made of galvanized steel sheet, press formed to a top hat shape, externally painted and internally insulated.

### Panels

Two types of panels,

- fixed panel
- access panel

1. Fixed panel  
Form the insulated enclosure of the case and give it rigidity and air-tightness, they consist of,
  - external sheet metal (outer skin)
  - insulation
  - internal protective cover (inner skin)

All panels come in *double-skin* configuration. The external galvanized sheet metal 24 or 20 gauge thickness (depending on panel size) is painted. The galvanized pre-coated internal protective cover over the insulation comes with galvanized 24 gauge solid steel sheet.

2. Access panel  
Constructed in similar manner as fixed panel with similar material. Three types are available,
  - *Removable panel* – fixed to frame with external screws for easy service access it comes as standard for coil section and fan section.
  - *Quick removable panel* – access panel secured to frames by latches for quick lift-off release and easy removable at filter section.
  - *Hinged door* – equipped with either latch or lock type to facilitate the maintenance and service at fan section or mixing box.
3. Paint  
Oven-baked gray polyester powder, 50 microns thick provides an excellent weather protection. Tested at different condition for gloss, adhesion, impact resistance and over-baked resistance. Salt spray 1000 Hrs resistance test, in compliance to ASTM B117.

### Thermal Insulation

Panels come with 40 kg/m<sup>3</sup> density injected polyurethane insulation as standard. The K-Value of the polyurethane insulation is 0.019 W/M.C

### Acoustical Insulation

The below table presents the acoustical insulation values based on **Eurovent** test labs.

O.B	125	250	500	1000	2000	4000	8000
db	9.4	11.4	12.4	11.8	16.4	31.1	32.5

### Sectioning Casing

Sectioning casing will be determined by selection software and it can be modified according to actual used. For special casing configuration, please contact your nearest *Carrier* office.

### Recommendations for External Installation

For exposed external installation a weatherproof roof, base frame and Protective inlet and discharge hoods are available as a factory installed options. The factory installed options can be selected by the *FlexAir* software.

Units are suitable for operation in external ambient temperatures of -30°C to +80°C.

## Dimensions

### GENERAL

The physical size and internal dimensions of the Air Handling Unit is determined by the number of modules. Each module has a constant dimension value of  $M = 315\text{mm}$ .

The length of the unit is found from the sum of component part (in modules) required.

*Example:*

Consider unit 39FX360 with 8 modules long,

Height =  $(3 \times 315 \text{ mm}) + (2 \times 50 \text{ mm}) = 1045 \text{ mm}$

Width =  $(6 \times 315 \text{ mm}) + (2 \times 50 \text{ mm}) = 1990 \text{ mm}$

Length =  $(8 \times 315 \text{ mm}) + (2 \times 50 \text{ mm}) = 2620 \text{ mm}$

Unit size	Number of modules			39FD box (mm)*		
	Height (H)	Width (W)	Max section	Height (H)	Width (W)	Max section
220	2	2	10	730	730	3250
230	2	3	10	730	1045	3250
240	2	4	10	730	1360	3250
330	3	3	10	1045	1045	3250
340	3	4	10	1045	1360	3250
350	3	5	10	1045	1675	3250
360	3	6	10	1045	1990	3250
370	3	7	10	1045	2305	3250
440	4	4	10	1360	1360	3250
450	4	5	10	1360	1675	3250
460	4	6	10	1360	1990	3250
470	4	7	10	1360	2305	3250
480	4	8	7	1360	2620	2305
550	5	5	10	1675	1675	3250
560	5	6	10	1675	1990	3250
570	5	7	10	1675	2305	3250
580	5	8	7	1675	2620	2305
660	6	6	10	1990	1990	3250
670	6	7	10	1990	2305	3250
680	6	8	7	1990	2620	2305
770	7	7	10	2305	2305	3250
780	7	8	7	2305	2620	2305
7100	7	10	7	2305	3250	2305
8100	8	10	7**	2620	3250	2305**
9100	9	10	7**	2935	3250	2305**
10100	10	10	7**	3250	3250	2305**
10120	10	12	7**	3250	3880	2305**
1212	12	12	7**	3880	3880	2305**
1215	12	15	7**	3880	4825	2305**

Notes:

\* Maximum length for a single standard section. No limit to the total number of sections used.

\*\* Non-standard for maximum single section length, please contact the factory for more details.

Dimensions do not include dampers, connections, extended coil, accessories, and other external or extended items.

# Dampers

## GENERAL

### Functions

1. Antifreeze (for minimal resistance leakage)
2. Two-way or three-way mixing
3. Bypass
4. Multizone

### Features

- Standard construction flange case frame from 1.5 mm galvanized steel sheet at both side.
- Less resistance sintered bronze (oilite) bushing and self lubricating bearings means free of maintenance.
- Oppose blades with single skin and laminar profile blade design provide low resistance to airflow. Parallel blade offered as option.
- Low standard leakage – (Class IV, according to UL555S).
- Low sound level and low air pressure losses with optional hollow aerodynamic profile damper blades.
- Low torque requirement and precise control with external spindle, side linkage and oppose blade operation.
- Non-welded damper blades made of GI material ensures corrosion resistant

Note: Standard dampers are supplied without positioning quadrant and handle.

### CONSTRUCTION

Steel frame, flanged but not drilled, from galvanized sheet steel.

Blades are galvanized steel sheet of single skin and laminar profile, designed to prevent twisting.

Wider blades are reinforced to ensure stronger blades at higher face velocity and minimized air leakage.

Shafts are made of 12mm dia, cadmium plated steel.

Bushings are from sintered bronze (oilite) or hard nylon, press-seated into the frame. Blades are interconnected by means of linkage and require low torque, even at high-pressure differential.

Interconnection on fresh, return and exhaust air dampers is made with pushrods that are delivered pre-installed by factory. Accessory actuators act on two or three extended shafts and are selected to match damper torque.

Damper spindle located either left or right hand upon request.

### RECOMMENDATIONS

Limits of application:

- Temperature  $-30^{\circ}\text{C}$  to  $+80^{\circ}\text{C}$
- Maximum pressure differential 2000 Pa
- Maximum velocity 9 m/s

### INSTALLATIONS

The dampers are located on the outside of mixing box section except on internal installations where dampers are internally mounted.

U-formed damper frame serves as a flange for ductwork connection.

### DAMPER SIZES

Standard 39F Air Handling Units damper sizes are as attached tables.

### DAMPER TORQUE

Damper size and torque is given by the *FlexAir* software.

# Dampers

Standard damper size

Height		Length (mm)										
		Module										
(mm)		1	2	3	4	5	6	7	8	9	10	
M o d u l e	1	183	183	498	813	1128	1443	1758	2073	2388	2703	3018
	2	498	183	498	813	1128	1443	1758	2073	2388	2703	3018
	3	813	183	498	813	1128	1443	1758	2073	2388	2703	3018
	4	1128	183	498	813	1128	1443	1758	2073	2388	2703	3018
	5	1443	183	498	813	1128	1443	1758	2073	2388	2703	3018
	6	1758	183	498	813	1128	1443	1758	2073	-	-	-
	7	2073	183	498	813	1128	1443	1758	2073	-	-	-

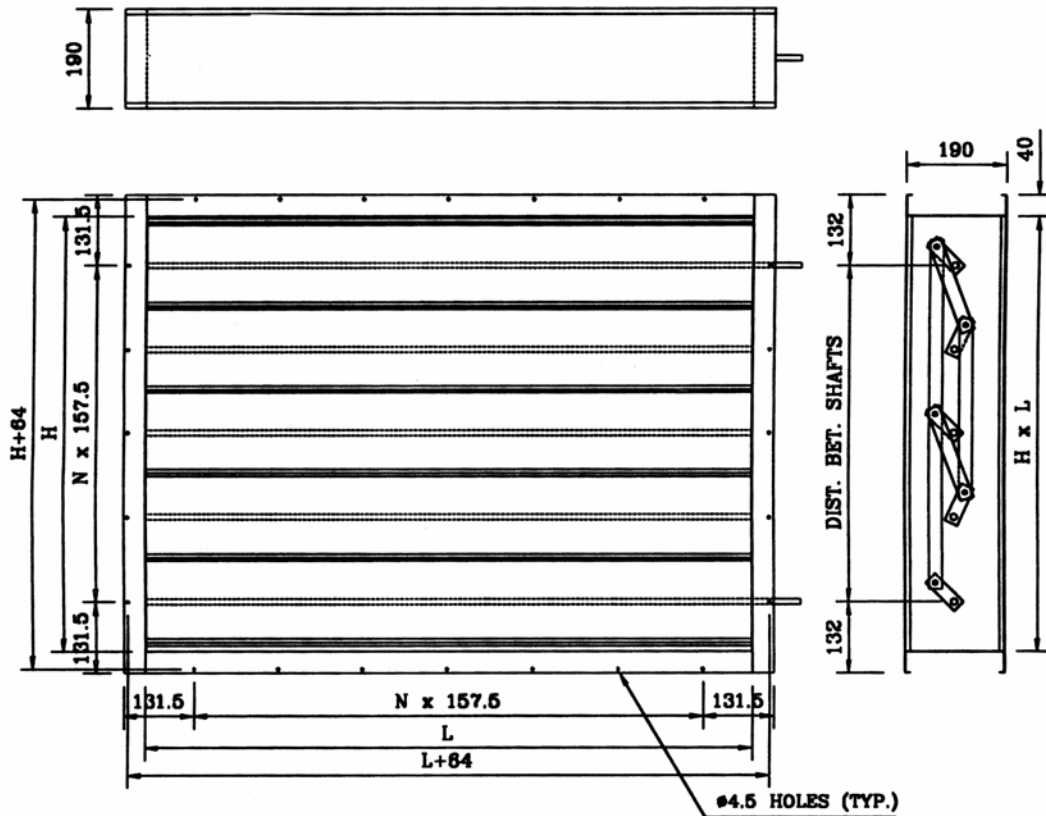

# Filters

## GENERAL

Recommended filters for 39F Air Handling Unit are tested by AFTL (American Filter Testing Laboratory) as per ASHRAE 52.1-1992 test method for performance, arrestance grade and flame protection. The media is made of synthetic polyester fiber (except for metallic filter media) with no electro-static present, non-flammable, washable and heat resistant up to 100°C.

Standard filter type for 39F Air Handling Units are:

- Flat pre-filter – 100% synthetic media, washable, flame retarded, and U.L. Class 2 Rated.
- Metallic – Aluminum media, washable and rust proof.
- V-pleated - 100% synthetic media, washable, flame retarded, and UL Class 2 Rated.

- Soft bag – Synthetic or fiber media, flame retarded, and U.L. Class 2 Rated (from 50% up to 65% Efficiency) and U.L. Class 1 Rated (from 85% up to 95% Efficiency).
- Rigid bag - Synthetic polyester media, flame retarded, and U.L. Class 1 and 2 Rated.
- Absolute – will depend to the application. Please contact *Carrier* office for further information.

It is important to know the type and size of particles in order to select the correct filter type. The chart below illustrates various type of particles and their sizes and some guidance for appropriate filter to be selected.

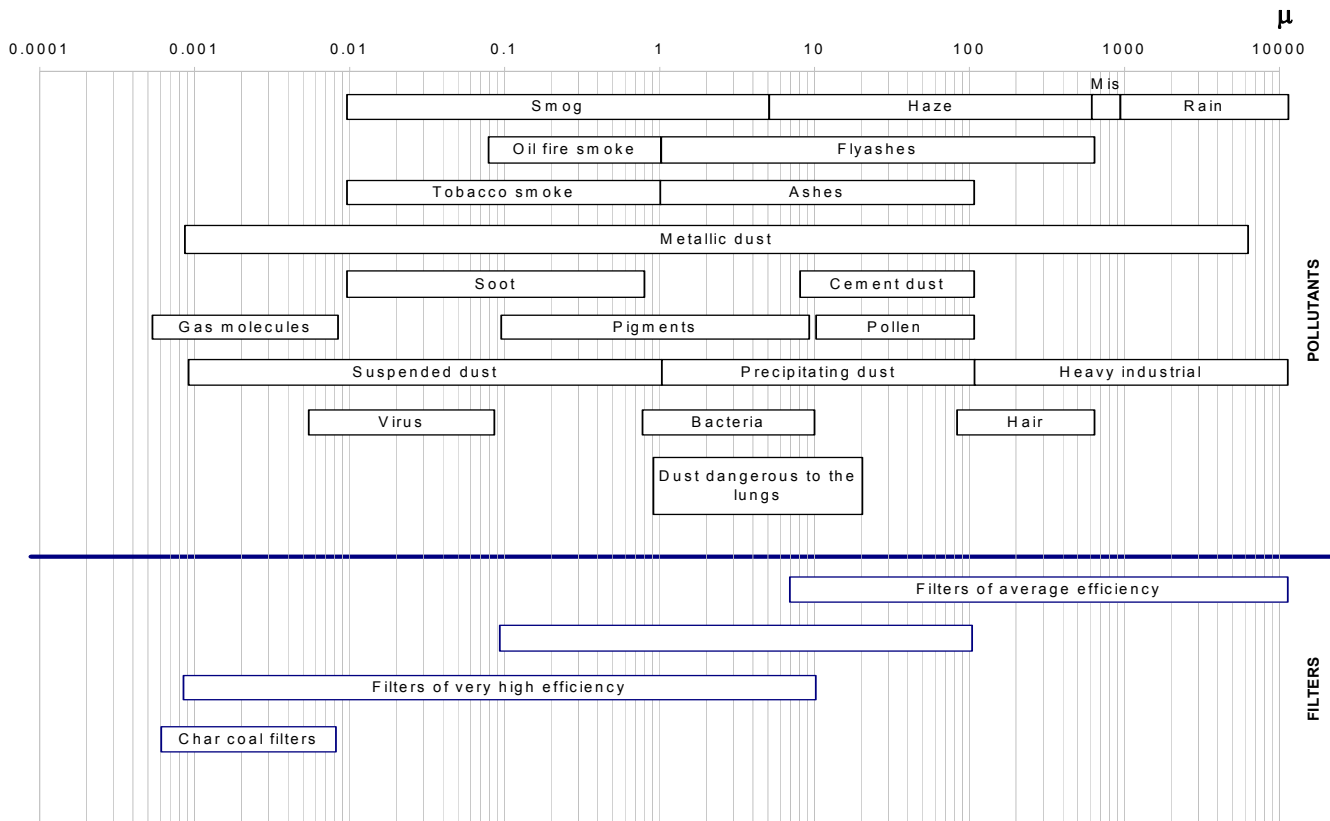

Type of particles in microns and recommended filters

# Filters

## FILTER CHARACTERISTICS

### Efficiency

The definition of filter efficiency is the capability of the filter to retain particles. The filter efficiency is supplied together with an indication of test method being used or else the definition is meaningless.

$$\text{Efficiency (\%)} = \frac{\text{quantity of retained dust}}{\text{total emitted quantity of dust}} \times 100$$

### Pressure drop

The loss pressure drop through filters is a function of the air velocity and the state of filter saturation. In selecting fans for air handling units, it is recommended that pressure loss through filters is taken as 150% of the pressure loss of clean filters.

### Saturation time

Saturation time is an indication of the capacity of the filter to hold a certain amount of dust during a given time and at a given air velocity. The saturation time depends on the degree of site pollution. This data is essential for establishing life expectancy and preservation of filter efficiency.

## ASHRAE 52.1-92 FILTER TEST METHOD

ASHRAE test method is the procedure by which practically all filter manufacturers describe the filter performance. Eurovent classification of filters established filter categories that based on ASHRAE test method. These categories are:

### Gravimetric efficiency

- EU1 = Arrestance less than 65%.
- EU2 = Arrestance from 65% up to 85%.
- EU3 = Arrestance from 85% up to 90%.
- EU4 = Arrestance Above 90% .

### Opocimetric efficiency

- EU4 = Dust Spot Efficiency up to 40%
- EU5 = Dust Spot Efficiency above 40% up to 60%
- EU6 = Dust Spot Efficiency above 60% up to 80%
- EU7 = Dust Spot Efficiency above 80% up to 90%
- EU8 = Dust Spot Efficiency above 90% up to 95%
- EU9 = Dust Spot Efficiency above 95%

### D.O.P (Diocetylphthalate)

- EU10 = Sodium Flame Efficiency from 95% to 99.9%.
- EU12 = Sodium Flame Efficiency from 99.97% to 99.99%.

Filter	Method of measure	Type of measure
Average efficiency	Relation to weight	Gravimetric
High efficiency	Relation to transparency	Opacimetric
Very high efficiency or absolute	Quantity of particles	Counting and DOP

*Method and type of measure*

### Filter standard comparison.

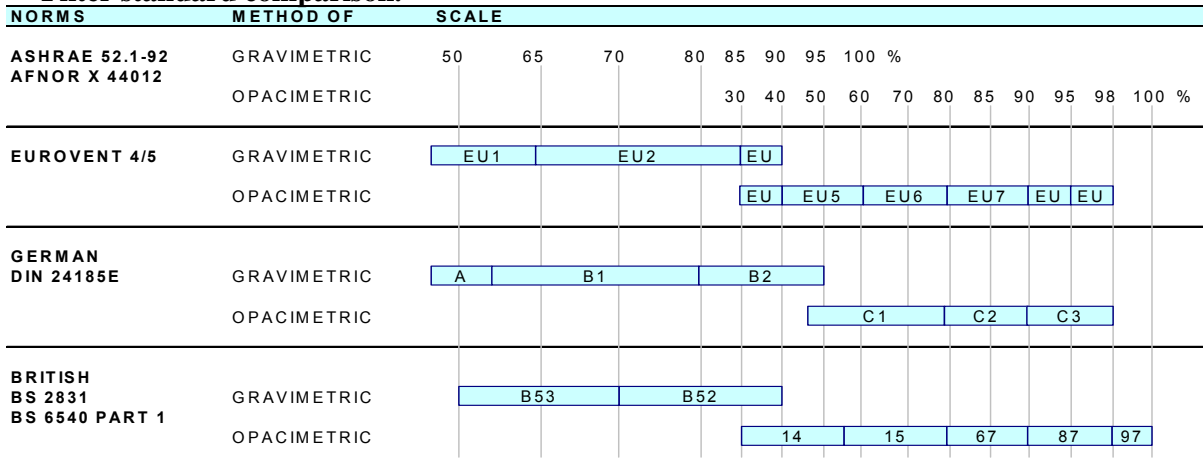

# Filters

## RECOMMENDATION

Filters should always be installed inside the air handling units. Absolute filters should be supplied with a prefilter of an opacimetric efficiency of 80 to 85%.

The amount of dust accumulated should regularly be checked by measuring the pressure drop across the filter and this should not exceed 300 Pa.

The pressure drop on absolute filters should not exceed twice the clean pressure loss. These recommendations refer to normal air contamination in average urban areas. Special solutions must be sought for air contamination created in industrial locations.

Filters exposed to high radiant temperature (above 120°C) such as steam coils, electric resistance heaters or similar, should be protected by inserting a heat rejecting screen between the heat source and the filter (optional feature).

## INSTALLATION

Two methods are available for filter installation depending on the type of filter:

1. In Slide Rails\*: this method is supporting the side withdrawal of the filters and its applicable for average efficiency filters, such as flat metallic filters, synthetic filters and Synthetic V-shape filters.

\*Note: the slide rails method is not applicable in case of Bag filters, Absolute filters and charcoal filters.

2. In Frames: this method can be used for front or rear withdrawal and its applicable for high and very high efficiency filters such as:
  - Bag filters, soft and rigid
  - Absolute filters
  - Charcoal filters

The use of prefilters (of average efficiency) is recommended to extend the life of high efficiency filters. These are mounted in frame for front withdrawal

Degree of Efficiency	Type of Filter	Efficiency	Installation		Filter Thickness mm	Face Velocity		Fire Class (ASHRAE 52.1-92)	Utilization Characteristics
			Frame	Slide Channel		Recomm m/s	Max m/s		
Average	Flat metallic	Gravimetric EU1 EU2	x	x	25 50	2.5	3.0	M1	Washable
	Flat synthetic	Gravimetric EU3	x	x	25	2.0	3.5	M1	Prefilter
	V Shape synthetic	Gravimetric EU4	x	x	50 75	2.5 2.5	3.0 3.0	M1 M1	Good relationship efficiency / space requirement
High	Soft bag	Opacimetric EU5 EU7 EU8	x x x		547	3.5	4.0	M1	Large air quantities
	Rigid bag	Opacimetric EU5 EU7 EU8	x x x		292	2.7	3.2	M1	Verticle Applications or or variable air flow
Very High	Absolute	D.O.P EU10 EU12	x		292	2.5	2.8	M1	Operating rooms or similar

*Type and characteristics of filter used in 39F units*

M1 : Non flammable

For special filter, please contact your nearest *Carrier* office.

# Fans

## GENERAL

Fans offered for the 39F Air Handling Units are from high performance centrifugal fans. The fan quality, airside and acoustics performances of the fans are tested in compliance with international standard either from AMCA or DIN. The fans are able to operate in a temperature range of -20°C to +80°C. Fan housing is made of galvanized steel; phosphated with lap joint and treated with high quality anti-corrosion protected.

### Fan Laws

For a given distribution system and specific air weight, the following laws in relation to volume, pressure and fan power applied dependent upon fan speed.

- The volume (V) changes as the fan speed (n) changes

$$V_2 = V_1 \frac{n_2}{n_1}$$

- The pressure (p) changes with the square of the speed (n)

$$P_2 = P_1 \left( \frac{n_2}{n_1} \right)^2$$

- The absorbed power (PW) changes with the cube of the speed (n)

$$Pw_2 = Pw_1 \left( \frac{n_2}{n_1} \right)^3$$

- As the specific weight of the air changes, the air quantities remain constant.
- The pressure and the absorbed power change with the specific weight ( $\eta$ ).

$$P_2 = P_1 \frac{\eta_2}{\eta_1} \quad \text{and} \quad Pw_2 = Pw_1 \frac{\eta_2}{\eta_1}$$

### Reference Values

The fan curves refer to a specific weight of 1.2 kg/m<sup>3</sup> at a temperature of 20°C at atmospheric pressure of 101.3 kPa (760 mm Hg) and a relative humidity of 50%.

## DESCRIPTION

### Types of Fans

39FX Air Handling Units are supplied with double inlet double width (DIDW) centrifugal blowers of either,

- forward curved
- backward curved
- airfoil curve

## Construction

- Fan casings are constructed of galvanized steel with a series of punched holes or nutserts allowing the fixing of accessories such as frames or support legs thus providing a variety of discharge positions.
- The impeller is galvanized finished for forward curve blade and epoxy painted for backward airfoil blade. All impeller are statically and dynamically balanced to the operating fan speed as a single unit to specification G25 in accordance to DIN ISO Standard 1940.
- Both forward and backward impellers are with laminar design and airfoil impellers are with aerodynamic design.
- Fans are securely fixed to mild steel shaft machined to close tolerance (g6) and coated with colored wax to protect from corrosion. Shafts are precision trued and ground. The drive side is machined to fit standard V-belt pulleys and the shaft ends are grooved and keyed.
- Types of bearing supplied as standard depend on fan class and size, and another type supplied as an option,
  - Standard Fan** - size 160 to 1000 for forward and backward curve fans (airfoil fan up to size 710). Radial insert ball bearings with spherical outer ring mounted within cast iron housing supported from the fan casing by tabular struts.
  - Option Fan** - size 400 to 1000 (reinforced airfoil fan). Self-aligning double row ball bearing secured by adapter sleeve, mounted within cast iron housing.
  - Option Fan** - size 400 to 1000 (option-super reinforced). Self-aligning double row ball bearings within standard plummer blocks, mounted on robust pedestal.

All bearings are pre-lubricated and maintenance free. Nominal life expectancy is designed up to 40,000 L<sub>10</sub> operating hours (according to DIN ISO 281 Section 1). Rated bearing life can reach up to 200,000 L<sub>10</sub> hours.
- Carrier* 39FX offers an optional Inlet Vane Controller / Inlet Guide Vane (IGV) depends on requirements and applications. The IGV is mounted directly inside each inlet cone with no external projection. The vane blades are non-aerofoil, galvanized metal pieces which run in plastic bearings to reduce chatter sound. The blades can be adjusted from 0 to 90° angle by a single actuator for double inlet or hand control if required.

# Fans

## INSTALLATION

Fan, motor and drives are mounted on a fan and motor base (FMB) that is isolated from the Air Handling Unit by a set of anti vibration isolators at the bottom and fan discharge is connected to the fan panel discharge with a fire retardant flexible connection. Supply air duct can be directly connected to the discharge panel flange.

Standard fan and motor casing is supplied with hinged access door at drive side.

## RECOMMENDATIONS

The air to be handled in the unit must be clean and non-corrosive.

Each Air Handling Unit can have a choice of several fan types with best efficiency and lowest sound level should be selected for a specific installation.

## FAN ARRANGEMENT

Fan installation for 39FD/FX comes in different arrangements as per application requirements. Different configurations are shown below.

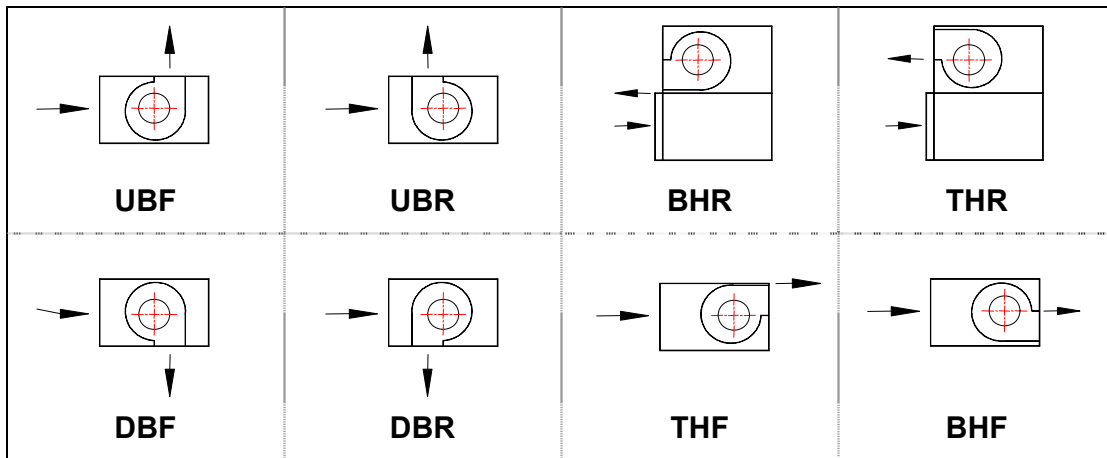

Fan arrangement

## FAN SHAFT SIZES – FORWARD, BACKWARD & (AIRFOIL)

Fan sizes	160	180	200	225	250	280	315	355
Diameter, mm	20(20)	20(20)	20(20)	20(20)	20(20)	25(24)	25(24)	25(24)

Fan sizes	400	450	500	560	630	710	800	900	1000
Diameter, mm	30(28)	30(28)	30(28)	40(38)	40(38)	50(48)	50(48)	60(55)	60(55)

## IGV TORQUE – BACKWARD & (AIRFOIL)

Fan sizes	355	400	450	500	560	630	710	800	900	1000
Torque <sub>max</sub> *, Nm	11	15(17)	20(25)	33(37)	35(39)	45(55)	65(78)	108(128)	131(157)	164(196)

\* Maximum torque at the pivot is reached at maximum fan speed and least favorable blade angle, figure include a safety margin

# Fans

## FAN OUTLET OPENING

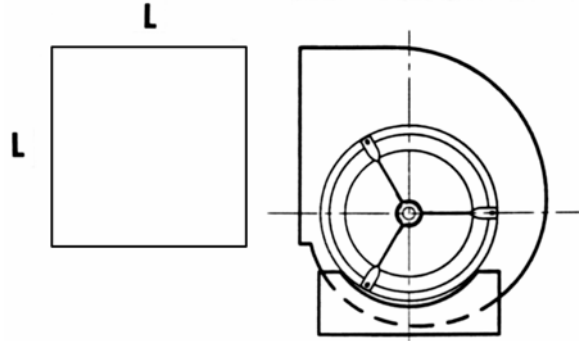

Fan Sizes	Forward	Backward	Aerofoil
	Fan Opening Dimension, L, mm		
160	203		
180	228		
200	253	254	
225	283	286	
250	318	320	
280	359	358	
315	404	401	
355	454	450	
400	504	504	506
450	564	566	570
500	634	635	639
560	714	712	715
630	804	798	802
710	905	894	897
800	1003		1006
900	1126		1129
1000	1263		1266
1120			1130
1250			1262
1400			1416
1600			1588

# Fans

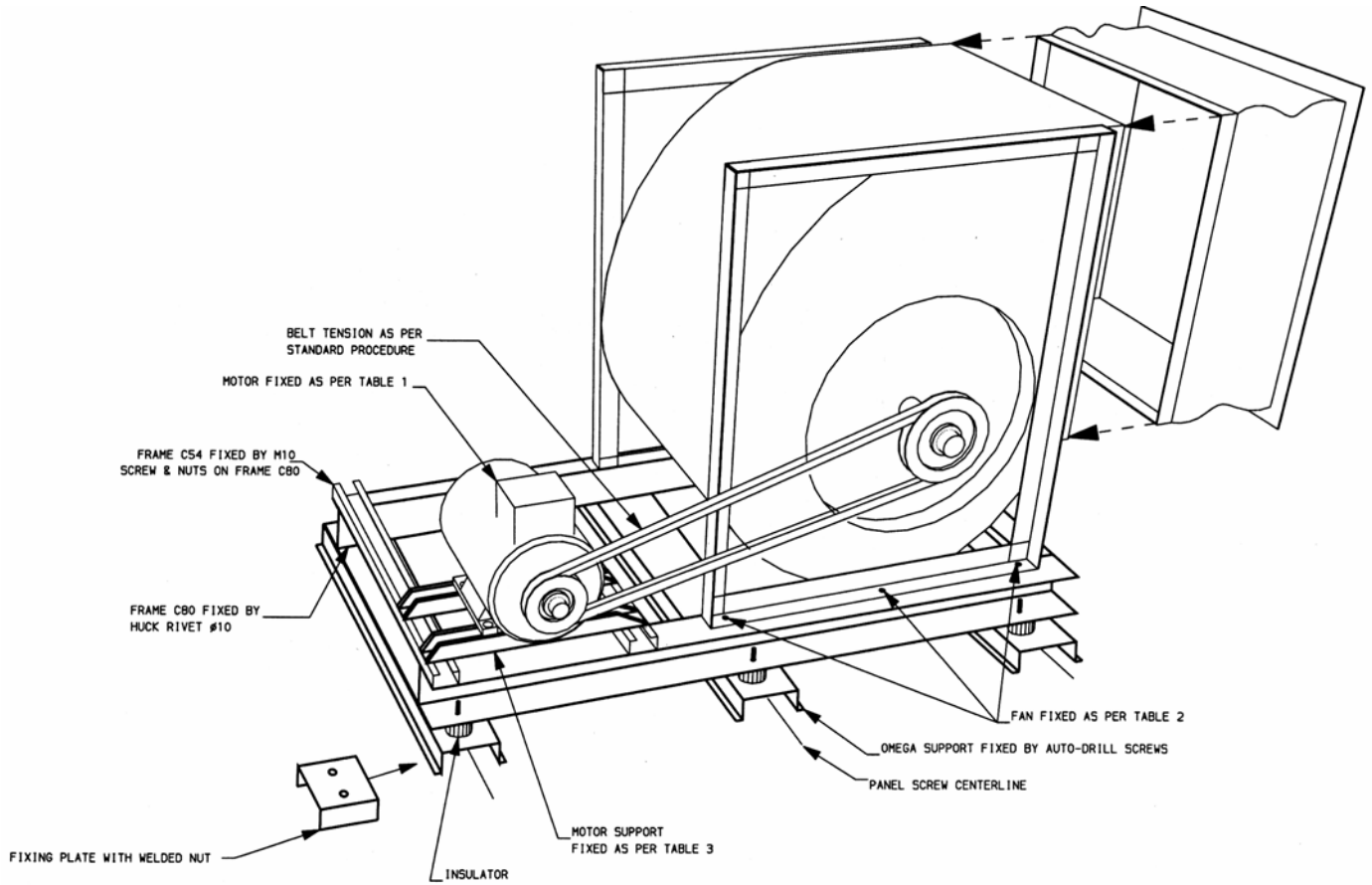

## Fan and Motor Assembly on the Fan and Motor Base (FMB)

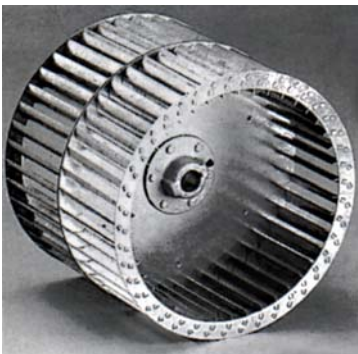

Forward curve impeller

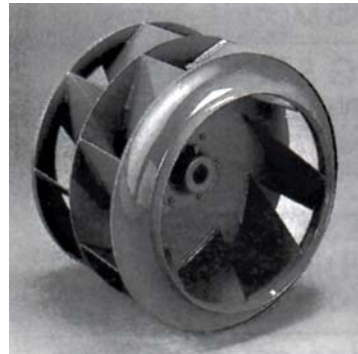

Backward curve impeller

# Motors

## Features

Standard features on motors used with *Carrier 39F* centrifugal fans are as below.

- Motors are of Totally Enclosed Fan Cooled (TEFC) type with finned casing surface.
- Index of Protection IP 55 that protect motor from dust and water.
- Metal frame from aluminum and steel for excellence heat transfer, strength and ruggedness.
- Single and dual speed motor.
- 3-phase, DOL, Star-Delta induction motor with six terminals.
- Dual speed motor with Delta Connection (please contact Carrier factory for this option).
- PTO (thermal overload protection – normally closed), protecting motor when temperature reaches 170°C
- Insulation class F at 40°C ambient temperature and continues duty.
- Voltage tolerance +/- 10% and frequency tolerance +/- 5%.
- Normal operating condition compliance with IEC 34-1 within ambient - 16<sup>0</sup>C and +40<sup>0</sup>C at below 1000 meter altitudes and at 1050 kPa (mbar) atmospheric pressure.
- Comply with IEC Standard with UL listing\*.

\* UL listing is for high efficiency motors only.

## Construction

Motors are with standard foot mounted, finned housing with integral feet of 4 to 6 screw holes. Shaft is from steel and shaft end fitted with screw and closed keyway. Motors are cooled as “ surface-cooled machine using the ambient air circulating round the machine” as per IEC 34.6 method IC 41. Terminal box is IP 55 protection. All standard motor are supplied with wiring diagram available in the terminal box. Earth terminal is located in the terminal box.

## Motor Sizing

Motor selection shall consider the mechanical losses in transmitting the load from motor shaft to fan shaft. Mechanical losses factor, K, are recommended as follow.

K = 1.15 for fan with brake kW is 10kW and below.

K = 1.10 for fan with brake kW is above 10kW.

Standard motor is with power supply 3ph/ 230V/400V/ 50Hz. Motor data published are based to these parameters. Other applications are also available, please contact *Carrier* office.

## Installation

Motor is mounted on an adjustable base so that belt tension can be easily adjusted. Dependent upon motor power and fan size the motor can be installed:

1. on the base frame at the back of the fan.
2. on the base frame at the side of the fan.
3. on the fan casing (max motor power 5.5 kW).

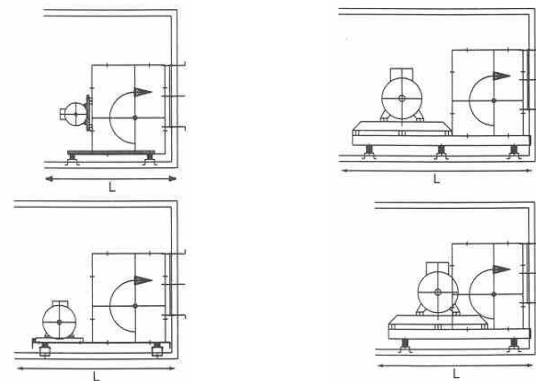

## Terminal block and connections

Standard motors are fitted with six terminals and these terminals are marked complying with IEC 34.8. Terminal connection and wiring diagrams are supplied in terminal box. Sample wiring connections are as below diagram.

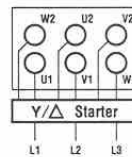
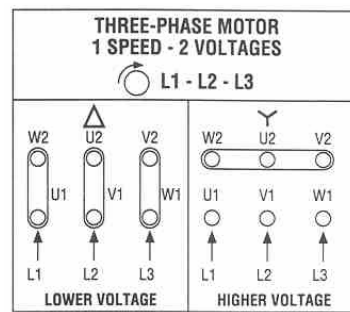

External wiring diagram

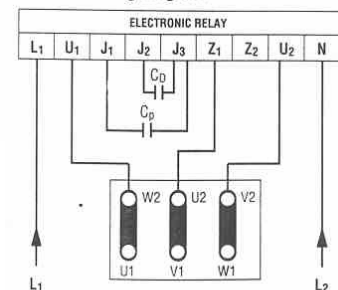

Note : to change the direction of rotation, connect W<sub>2</sub> motor to U<sub>2</sub> relay terminal, V<sub>2</sub> motor to U<sub>1</sub> relay terminal.

# Motors

## 2 – Poles 50Hz Motors

Rated power		Full load speed in revolutions per minute	Frame reference and size	Full load current at rated voltage			Efficiency			Power factor			Direct on line starting current ratio
PN				Type	380 V	400 V	415 V	$\eta$	$\eta$	$\eta$	Cos $\emptyset$	Cos $\emptyset$	
kW	hp	n min <sup>-1</sup>	A		A	A	1.0 PN	0.75 PN	0.5 PN	1.0 PN	0.75 PN	0.5 PN	IA IN
0.18	0.25	2760	T-DA63MA	0.53	0.51	0.51	63.0	62.0	57.7	0.81	0.76	0.67	4.6
0.25	0.33	2750	T-DA63MB	0.70	0.66	0.66	65.5	64.2	60.6	0.83	0.76	0.67	4.8
0.37	0.5	2825	T-DA71MA	1.0	0.95	0.95	71.2	71.0	66.9	0.79	0.74	0.62	4.9
0.55	0.75	2825	T-DA71MB	1.34	1.27	1.27	75.1	73.1	69.0	0.83	0.72	0.60	5.6
0.75	1.0	2860	T-DA(DF)80MA	1.81	1.73	1.73	76.4	75.5	70.3	0.82	0.76	0.61	5.8
1.1	1.5	2855	T-DA(DF)80MB	2.67	2.54	2.54	77.1	77.4	74.5	0.81	0.78	0.67	5.8
1.5	2.0	2855	T-DA(DF)90SA	3.4	3.2	3.2	80.5	80.8	78.0	0.84	0.79	0.67	6.4
2.2	3.0	2845	T-DA(DF)90LA	4.8	4.6	4.6	81.2	81.3	79.0	0.85	0.79	0.71	6.5
3.0	4.0	2855	T-DA(DF)100LA	6.1	5.8	5.8	82.9	83.0	80.5	0.90	0.85	0.76	6.6
4.0	5.5	2880	T-DA(DF)112MA	8.1	7.7	7.7	84.2	84.7	83.3	0.89	0.86	0.80	6.9
5.5	7.5	2885	T-DA(DF)112MB	10.5	10.0	10.0	87.0	87.9	84.1	0.91	0.85	0.79	7.2
5.5	7.5	2885	T-DA(DF)132SA	10.8	10.3	10.3	85.9	86.0	84.7	0.90	0.86	0.79	7.7
7.5	10	2900	T-DA(DF)132SB	15.2	14.5	14.5	87.0	87.6	86.4	0.86	0.83	0.79	7.3
11	15	2910	T-DA(DF)132M	21.3	20.2	20.2	89.1	89.5	88.7	0.88	0.86	0.80	7.5
11	15	2926	T-DA(DF)160MA	20.8	19.8	19.8	89.2	89.0	87.0	0.90	0.87	0.81	7.4
15	20	2930	T-DA(DF)160MB	28.8	27.4	27.4	89.8	90.0	88.7	0.88	0.87	0.81	7.1
18.5	25	2930	T-DA(DF)160LA	36	34	34	90.3	90.3	89.1	0.87	0.84	0.81	7.2
22	30	2954	T-DA(DF)180MA	40	38	38	90.5	89.7	87.3	0.93	0.87	0.80	7.3
30	40	2955	T-DA(DF)200LA	56	53	51	91.4	91.1	89.8	0.89	0.87	0.82	6.5
37	50	2940	T-DA(DF)200LB	68	64	62	92.0	92.0	90.9	0.90	0.87	0.81	7.0
45	60	2953	TU-DF225M	81	77	74	92.5	92.6	91.7	0.91	0.89	0.86	7.0
55	75	2965	TU-DF250M	100	95	91	93.0	92.7	91.4	0.90	0.89	0.84	7.6
75	100	2970	TU-DF250MB	138	131	126	93.9	93.6	92.2	0.88	0.86	0.80	7.0
75	100	2968	TU-DF280S	133	127	122	93.6	93.4	92.3	0.91	0.89	0.85	7.0
90	125	2972	TU-DF280MA	159	152	146	94.1	93.8	92.6	0.91	0.91	0.85	6.8

## 4 – Poles 50Hz Motors

Rated power		Full load speed in revolutions per minute	Frame reference and size	Full load current at rated voltage			Efficiency			Power factor			Direct on line starting current ratio
PN				Type	380 V	400 V	415 V	$\eta$	$\eta$	$\eta$	Cos $\emptyset$	Cos $\emptyset$	
kW	hp	n min <sup>-1</sup>	A		A	A	1.0 PN	0.75 PN	0.5 PN	1.0 PN	0.75 PN	0.5 PN	IA IN
0.18	0.25	1370	T-DA63MB	0.61	0.58	0.58	62.9	60.1	52.9	0.71	0.61	0.48	3.5
0.25	0.33	1375	T-DA71MA	0.8	0.76	0.76	67.5	65.5	60.9	0.70	0.63	0.54	4.0
0.37	0.5	1375	T-DA71MB	1.11	1.06	1.06	71.2	69.5	65.2	0.71	0.63	0.53	4.0
0.55	0.75	1410	T-DA(DF)80MA	1.5	1.5	1.5	72.6	72.6	69.2	0.73	0.67	0.54	4.6
0.75	1.0	1400	T-DA(DF)80B	1.98	1.89	1.89	74.3	74.3	69.7	0.77	0.64	0.48	4.4
1.1	1.5	1390	T-DA(DF)90SA	2.98	2.84	2.84	76.6	79.1	75.4	0.73	0.68	0.50	4.8
1.5	2.0	1390	T-DA(DF)90LA	3.6	3.5	3.5	78.9	79.8	77.7	0.79	0.70	0.56	4.8
2.2	3.0	1415	T-DA(DF)100LA	5.1	4.8	4.8	81.0	82.0	80.8	0.81	0.74	0.61	5.5
3.0	4.0	1415	T-DA(DF)100LB	6.7	6.4	6.4	82.6	84.2	84.2	0.82	0.75	0.64	5.3
4.0	5.5	1420	T-DA(DF)112MA	9.0	8.6	8.6	84.2	86.1	85.9	0.80	0.76	0.65	6.0
5.5	7.5	1440	T-DA(DF)132SA	11.8	11.3	11.3	85.8	86.8	85.5	0.82	0.77	0.65	6.6
7.5	10	1445	T-DA(DF)132MA	14.6	14.6	14.6	87.1	87.4	86.8	0.85	0.79	0.74	7.1
11	15	1445	T-DA(DF)132MB	22.7	21.6	21.6	88.4	88.4	86.5	0.83	0.80	0.71	7.1
11	15	1450	T-DA(DF)160MA	21.1	21.1	21.1	88.4	88.9	87.9	0.85	0.81	0.72	6.4
15	20	1455	T-DA(DF)160LA	29.6	28.2	28.2	89.4	90.1	88.4	0.86	0.82	0.73	7.4
18.5	25	1465	T-DA(DF)180MA	37	35	35	90.0	90.0	88.6	0.85	0.80	0.70	7.0
22	30	1460	T-DA(DF)180LA	43	41	41	90.5	90.6	89.8	0.86	0.80	0.71	6.8
30	40	1470	T-DA(DF)200L	57	54	54	91.4	91.3	90.3	0.88	0.85	0.78	6.5
37	50	1477	TU-DF225S	71	67	65	92.0	92.2	91.1	0.86	0.86	0.83	6.5
45	60	1477	TU-DF225M	86	82	78	92.5	92.6	91.6	0.86	0.86	0.78	6.8
55	75	1470	TU-DF250MA	102	97	93	93.0	93.2	92.7	0.88	0.84	0.78	6.7
75	100	1481	TU-DF250MB	141	134	129	93.6	93.4	92.4	0.86	0.83	0.76	6.5
75	100	1481	TU-DF280S	136	130	125	93.6	93.7	92.9	0.89	0.87	0.81	6.2
90	125	1475	TU-DF280MA	165	157	151	93.9	94.0	93.6	0.88	0.86	0.82	6.5

# Drives

Transmission of power from fan motor to fan is provided by means of a set of pulleys and matching v-belts. The pulleys are taperlocked to the fan and motor shaft. Optional variable pitch pulley fixed to the motor shaft is available for motor size up to 11 kW. Carrier 39F Air Handling Units are supplied with optimized pulleys and belts sizes and pre-installed by factory. Proper drives sizing and installation will ensure fan to rotate at required designed speed and at the same time help to optimize fan and motor bearing life.

### Pulley with taper bushing

Common pulleys supplied in 39F Air Handling Units are:

1. Block pulleys
2. Web pulleys
3. Arm pulleys

### Wedge belts

Common wedge belts supplied in 39F Air Handling Units are:

1. SPA – 13W X 8H X Length
2. SPB – 17W X 11H X Length
3. SPC – 22W X 14H X Length
4. SPD – 32W X 19H X Length
5. SPZ – 10W X 6H X Length

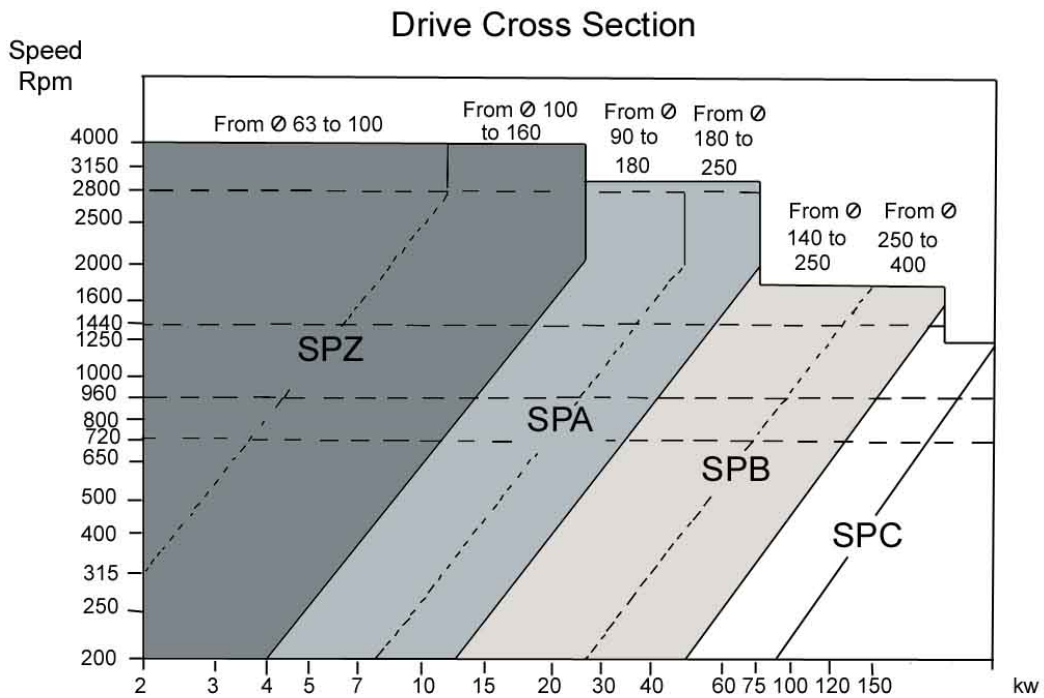

Common pulleys for wedge belts (SPA, SPB and SPZ) application.

# Coils

## STANDARD FEATURES

- Carrier 39F Air Handling Units offering several coil applications such as chilled water, hot water, direct expansion (DX) and steam coil.
- Coil performance is rated and certified to ARI. 410.
- Coil designed and manufactured as per *Carrier* Standard and according to ANSI and DIN Standard.
- Coils come in a cartridge type construction with a single pair as standard or dual connection pairs as option.
- Header and connection for DX coil is made of copper with sweat connection.
- Water coils are with copper header and steel tube connection, threaded end (11 TPI) or Copper tube sweet connection.
- All water coil headers are equipped with drain and vent connections.
- Tubes are mechanically expanded to collar fins.
- Slide-in and slide-out construction on coil track provides easy coil removal for service and maintenance.
- Coils are factory tested at 30 Bar and maximum working pressure is 20 Bar.
- All coils shall have counter flow arrangement.
- Coil frames are from galvanized steel and painted.
- DX coil is equipped with distributor head and tube feeders to the coil circuiting.

Other coil specifications and features please contact your nearest *Carrier* office.

## SELECTION

Coil selection can be done thru the *FlexAir* software.

## RECOMMENDATIONS

For standard or customized coils, recommended maximum allowable face velocity is:

$v = 4.5\text{m/s}$	heating coil or dry coil
$v = 3.15\text{m/s}$	dehumidifying cooling coils with droplet eliminator
$v = 2.6\text{m/s}$	dehumidifying cooling coils without droplet eliminator

Where necessary, a droplet eliminator is automatically included by the computer selection program. Water circuits provided for standard coils are factory selected to limit the pressure loss to 30 ft (90 kPa) on hot water coils and to 45 ft (140 kPa) on chilled water coils.

A U-trap of height equal to twice the fan static pressure must be provided on site by installer. This

will ensure proper flow of condensate water out from the drain pan.

## CONDENSATE DRAIN PAN

Condensate drain pan shall be from galvanized, minimum spangle G90 material and internally painted. The drain pan is mounted onto a slider track with drain pan with bottom sloped to ensure complete and positive drainage to meet with ASHRAE 62-89 requirement. Insulated bottom drain pan is available as standard.

## COIL CONSTRUCTION AND INSTALLATION

Chilled water coils are assembled and installed either in two modules length coil casing or in five modules length coil casing depending on the coil size. Hot water coil or other dry coil application required only one module casing length. For wet coil application, the coil mounted inside a drain pan. The top end of the coil and the bottom drain pan are supported with Z-Profiles to secure the coil in position. Z-Profiles also allow sliding the coil and drain pan to ease installation and coil maintenance works. Coil casings are with external mounting screw panels access for maintenance purposes.

## STANDARD DRAIN PAN FEATURES AND ADVANTAGES

- Single skin drain pan
- Internally assembled inside coil section without exposed to high ambient temperature to prevent condensation.
- Fully insulated and seal underneath pan to prevent air-by-pass
- Made of minimum spangle grade G90 galvanize steel and powder painted internally for additional corrosion resistance
- Stainless steel grade S304 drain pan available as option
- Slope at one-sided to provide positive drainage of condensate water
- Single drain pipe connection, 1 ¼ inch threaded steel pipe towards header side

## STANDARD ELIMINATOR FEATURES AND ADVANTAGES

- Cartridge type, fully assemble and directly attaché to coil frames
- Frame made of galvanize steel
- Blades made of MRP PVC for highest corrosion resistance.
- Blade's profile designed for lower pressure drop and highest efficiency

# Coils

## STANDARD ELIMINATOR FEATURES AND ADVANTAGES

- Cartridge type, fully assemble and directly attaché to coil frames
- Frame made of galvanize steel
- Blades made of MRP PVC for highest corrosion resistance
- Blade’s profile designed for lower pressure drop and highest efficiency

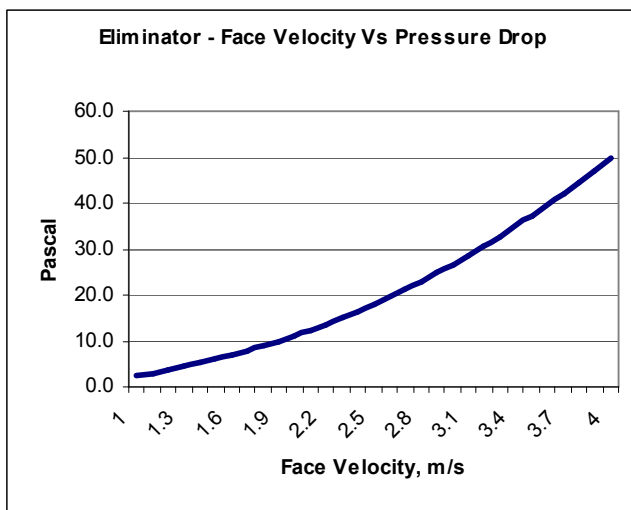

Note:  
Eliminator selection is done automatically by Flex Air Program.

### Water Weight for Different Coil Size.

No	AHU Size	Coil Number of Row Vs Water Weight, Kg						
		2	3	4	5	6	7	8
1	220	2.1	3.2	4.2	5.3	6.3	7.4	8.4
2	230	3.7	5.5	7.3	9.2	11.0	12.9	14.7
3	240	5.1	7.6	10.2	12.7	15.3	17.8	20.3
4	330	6.3	9.4	12.6	15.7	18.9	22.0	25.2
5	340	8.7	13.1	17.4	21.8	26.2	30.5	34.9
6	350	11.6	17.4	23.2	29.0	34.8	40.6	46.5
7	360	14.0	21.1	28.1	35.1	42.1	49.1	56.2
8	370	16.7	25.1	33.4	41.8	50.2	58.5	66.9
9	440	12.4	18.5	24.7	30.9	37.1	43.2	49.4
10	450	16.5	24.7	32.9	41.1	49.4	57.6	65.8
11	460	19.9	29.8	39.8	49.7	59.7	69.6	79.6
12	470	23.7	35.5	47.4	59.2	71.1	82.9	94.7
13	480	27.5	41.2	55.0	68.7	82.4	96.2	109.9
14	550	21.3	31.9	42.6	53.2	63.9	74.5	85.2
15	560	25.7	38.6	51.5	64.3	77.2	90.1	103.0
16	570	30.7	46.0	61.3	76.6	92.0	107.3	122.6
17	580	35.6	53.3	71.1	88.9	106.7	124.5	142.3
18	660	31.6	47.4	63.2	79.0	94.8	110.6	126.3
19	670	37.6	56.4	75.2	94.0	112.9	131.7	150.5
20	680	43.6	65.5	87.3	109.1	130.9	152.8	174.6
21	770	44.6	66.9	89.2	111.5	133.8	156.0	178.3
22	780	51.7	77.6	103.5	129.3	155.2	181.1	206.9
23	7100	66.0	99.0	132.0	165.1	198.1	231.1	264.1
24	8100	90.8	136.2	181.6	227.0	272.4	317.7	363.1
25	9100	111.4	167.1	222.8	278.5	334.3	390.0	445.7
26	10100	132.0	198.1	264.1	330.1	396.1	462.2	528.2
26	10120	161.1	241.6	322.2	402.7	483.3	563.8	644.4

# Coils

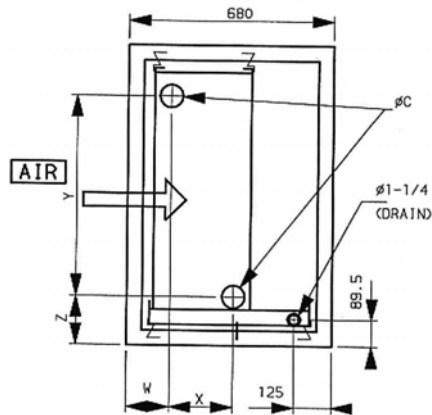

Standard Stag 1/2" Coils - Header Connection Pipe Sizes & Position

AHU Sizes	Number Of Row (s)	Number Of Circuit (s)	Steel Header Connection Pipe ID. Inch	Copper Header Connection Pipe OD. Inch	X	Y	Z
220, 230, 240	1	7	1 1/4	2 1/8	92	364	165
	2	7	1 1/4	2 1/8	66	379	165
	2	14	1 1/2	2 1/8	66	367	165
	4	7	1 1/2	2 1/8	60	367	165
	4	14	1 1/2	2 1/8	60	367	165
	6	7	1 1/2	2 1/8	99	367	165
	6	14	1 1/2	2 1/8	99	367	165
	6	21	1 1/2	2 1/8	99	367	165
	8	7	1 1/2	2 1/8	139	367	165
	8	14	1 1/2	2 1/8	139	367	165
330, 340, 350, 360, 370	1	12	1 1/4	2 1/8	92	682	165
	2	12	1 1/4	2 1/8	66	697	165
	2	24	1 1/2	2 1/8	66	685	165
	4	12	1 1/2	2 1/8	60	685	165
	4	24	1 1/2	2 1/8	60	685	165
	6	12	1 1/2	2 1/8	99	685	165
	6	24	1 1/2	2 1/8	99	685	165
	6	36	1 1/2	2 1/8	99	685	165
	8	12	1 1/2	2 1/8	139	685	165
	8	24	1 1/2	2 1/8	139	685	165
440, 450, 460	1	17	1 1/4	2 1/8	92	999	165
	2	17	1 1/4	2 1/8	66	1014	165
	2	34	1 1/2	2 1/8	66	1002	165
	4	17	1 1/2	2 1/8	60	1002	165
	4	34	1 1/2	2 1/8	60	1002	165
	6	17	1 1/2	2 1/8	99	1002	165
	6	34	1 1/2	2 1/8	99	1002	165
	6	51	1 1/2	2 1/8	99	1002	165
	8	17	1 1/2	2 1/8	139	1002	165
	8	34	1 1/2	2 1/8	139	1002	165
470, 480	1	17	1 1/4	2 1/8	92	999	165
	2	17	1 1/4	2 1/8	66	1014	165
	2	34	1 1/2	2 1/8	66	1002	165
	4	17	3	4 1/8	109	969	165
	4	34	3	4 1/8	109	969	165
	6	17	3	4 1/8	119	969	165
	6	34	3	4 1/8	119	969	165
	6	51	3	4 1/8	149	969	165
	8	17	3	4 1/8	139	969	165
	8	34	3	4 1/8	139	969	165
8	68	3	4 1/8	139	969	165	

# Coils

AHU Sizes	Number Of Row (s)	Number Of Circuit (s)	Steel Header Connection Pipe ID. Inch	Copper Header Connection Pipe OD. Inch	X	Y	Z
550	1	22	1 1/2	2 1/8	92	1305	165
	2	22	1 1/2	2 1/8	66	1320	165
	2	44	1 1/2	2 1/8	66	1320	165
	4	22	1 1/2	2 1/8	60	1320	165
	4	44	1 1/2	2 1/8	60	1320	165
	6	22	1 1/2	2 1/8	99	1320	165
	6	44	1 1/2	2 1/8	99	1320	165
	6	66	1 1/2	2 1/8	99	1320	165
	8	22	1 1/2	2 1/8	139	1320	165
	8	44	1 1/2	2 1/8	139	1320	165
560, 570, 580	1	22	1 1/2	2 1/8	92	1315	165
	2	22	1 1/2	2 1/8	66	1320	165
	2	44	1 1/2	2 1/8	66	1320	165
	4	22	3	4 1/8	109	1286	165
	4	44	3	4 1/8	109	1286	165
	6	22	3	4 1/8	119	1286	165
	6	44	3	4 1/8	119	1286	165
	6	66	3	4 1/8	149	1286	165
	8	22	3	4 1/8	139	1286	165
	8	44	3	4 1/8	139	1286	165
660	1	27	2 1/2	3 1/8	92	1602	165
	2	27	2 1/2	3 1/8	66	1617	165
	2	54	2 1/2	3 1/8	66	1617	165
	4	27	3	4 1/8	60	1604	165
	4	54	3	4 1/8	60	1604	165
	6	27	3	4 1/8	99	1604	165
	6	54	3	4 1/8	99	1604	165
	6	81	3	4 1/8	99	1604	165
	8	27	3	4 1/8	139	1604	165
	8	54	3	4 1/8	139	1604	165
670, 680	1	27	2 1/2	3 1/8	92	1602	165
	2	27	2 1/2	3 1/8	66	1617	165
	2	54	2 1/2	3 1/8	66	1617	165
	4	27	3 1/2	4 1/8	109	1591	165
	4	54	3 1/2	4 1/8	109	1591	165
	6	27	3 1/2	4 1/8	119	1591	165
	6	54	3 1/2	4 1/8	119	1591	165
	6	81	3 1/2	4 1/8	149	1591	165
	8	27	3 1/2	4 1/8	139	1591	165
	8	54	3 1/2	4 1/8	139	1591	165
770, 780, 7100	1	32	2 1/2	3 1/8	84	1919	165
	2	32	2 1/2	3 1/8	82	1934	165
	2	64	2 1/2	3 1/8	82	1934	165
	4	32	3 1/2	4 1/8	109	1908	165
	4	64	3 1/2	4 1/8	109	1908	165
	6	32	3 1/2	4 1/8	119	1908	165
	6	64	3 1/2	4 1/8	119	1908	165
	6	96	3 1/2	4 1/8	149	1908	165
	8	32	3 1/2	4 1/8	139	1908	165
	8	64	3 1/2	4 1/8	139	1908	165
8	128	3 1/2	4 1/8	139	1908	165	

# Electric Heaters

## General

- Electric heater shall be of the cartridge type.
- Heaters shall be framed with a slide in-out track so that the complete assembly is removable.

## Closed Tubular Finned Heater Type (option)

- Heating element is made of composition 80% Ni and 20% Cr.
- Assembly of the heating element is secured inside the stainless steel spherical sheathed fins copper tube.
- Heating component is according to AISI 321 and AISI 430.
- Heating elements are wired in star or delta according to the power supply and pre wired to the terminal block in the wiring box.

## Primary and secondary overheat protection

- Automatic and manual reset thermal overload installed.
- Airflow switch installed to interlock fan with heater.

## Access Panel

- Totally removable panel shall be assembled at both casing wall and bolted externally for airtightness, easy remove and reassemble panel to facilitate access for servicing and maintenance.

## SELECTION

### Example:

- Unit 39FD 570 with 8300 l/s.
- Temperature increase of 12°C is required.
- Heating load  
 $Q = 1.21 \times \Delta t \times V$   
 $Q = 1.21 \times 12 \times 8300 = 120,500 \text{ W}$
- From Standard Heater Table, 105 kW would result in 10.5°C temperature increase or 126 kW would result in 12.5°C temperature increase.

With either selection a four-step control is feasible. Non-standard heater size and non-standard heater steps are also available. Please consult *Carrier* office for non-standard heater requirements.

TYPICAL ELECTRIC HEATER WIRING DIAGRAM

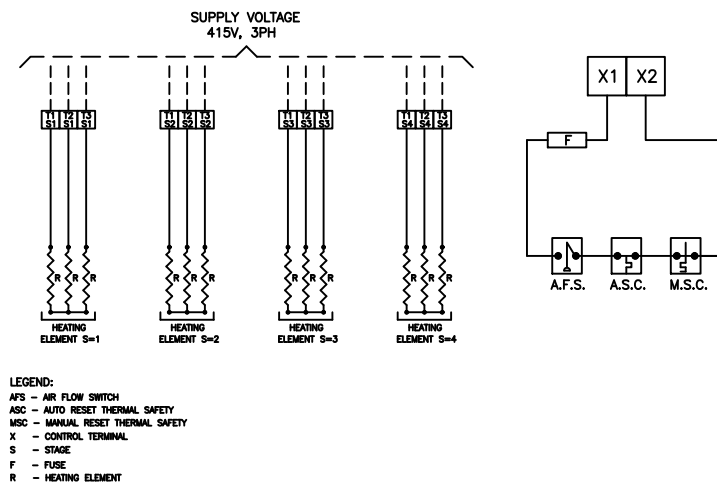

# Electric Heaters

## Closed Type Heater

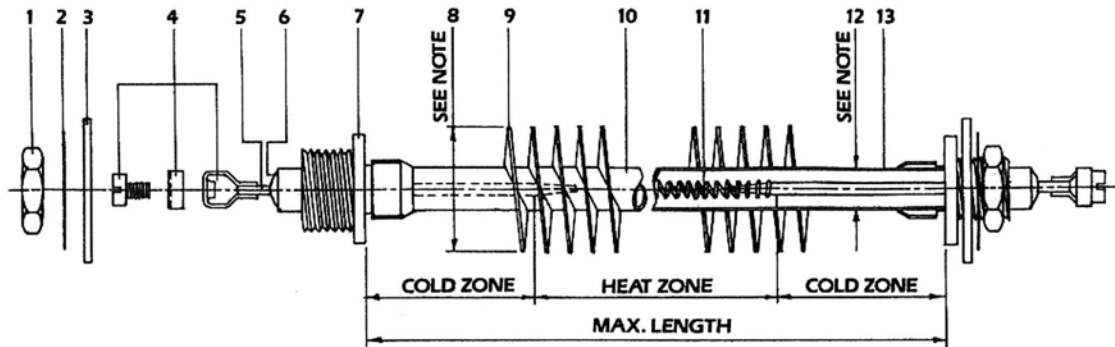

1. Brass  $\frac{3}{8}$ " BSP Locknut.
2. Optional identification disc.
3. Galvanised washer.
4. Stainless steel terminal, includes screw and washer.
5. Steel terminal pin.
6. High quality seal to prevent ingress of moisture.
7. Zinc plated steel press on bush,  $\frac{3}{8}$ " BSP complete with locknut and washer.
8. Outside fin diameter
  - (a) 11mm Series = 31.75mm O.D.
  - (b) 8mm Series = 22mm O.D.
9. Continuous wound steel fins assure excellent heat transfer and help prevent fin vibration at high air velocities.
  - (a) Fins 2 turns per cm (10mm  $\varnothing$  Series)
  - (b) Fins 2 turns per cm (8mm  $\varnothing$  Series)
10. Element coated in high temperature Alum paint, cured at high temperatures to prevent hazardous fumes when energised.
11. Nickel chrome helix wire
12. (a) Heavy duty steel tube (11mm  $\varnothing$  Series)
- (b) Heavy duty steel tube (8mm  $\varnothing$  Series)
13. Stamped Cat. No., wattage and voltage.
- 14 Cold Zone: Standard length 75mm.
- 15 Max. Length:Based on straight length
  - (a) 11mm Series = 6500mm.
  - (b) 8mm Series = 6300mm.
- 16 Maximum operating temperature of standard elements = 100°C in air.  
For special applications where higher operating temperatures are required please contact the manufacturer.

# Energy Recovering System

## GENERAL

The energy recovering system in AHU can be applied in both two applications

1. Recover thermal energy from exhaust air and use to lower down fresh air temperature
2. Pre-cooled and Re-heating to reach comfort conditions
3. Combination of Recovery with Pre-Cool & Re-Heat

Advantages Of Energy Recovering System In AHU

- Lowering first cost of HVAC Package
- Improve indoor air quality
- Reduce ventilation energy cost
- Recover latent and sensible energy
- Saving HVAC operating cost
- Operate for summer and winter seasons

Four types of energy recoveries equipment are

1. Heat Wheel (HWE) → can recover latent and sensible energy
2. Heat Plate recuperator (HPE) → recover sensible energy only
3. Run Around Coil (RAC) → recover sensible energy only
4. Heat Pipe (HPHS, HPR) → recover sensible energy only

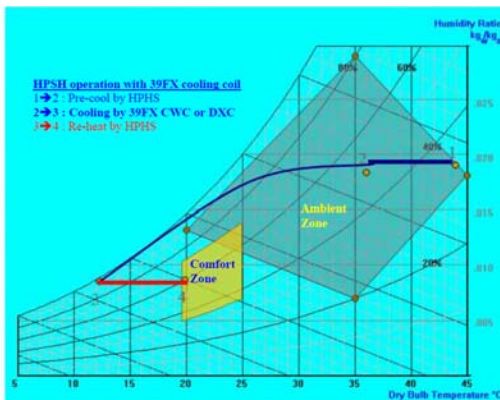

Note:

HPHS : Heat Pipe horse shoe

HPR : Heat Pipe recovery

Energy Recovery System selections and performances can be done with Flex Air Selection Program. Some common applications shown below.

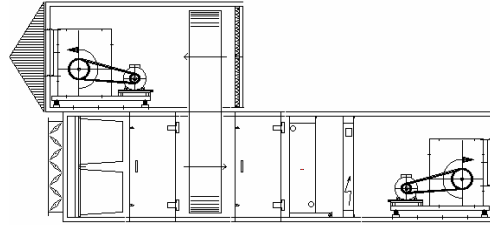

Recovery with HWE

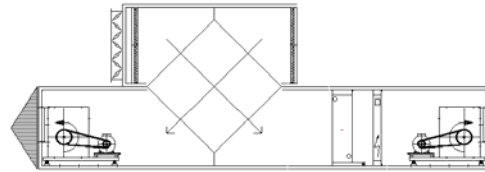

Recovery with HPE

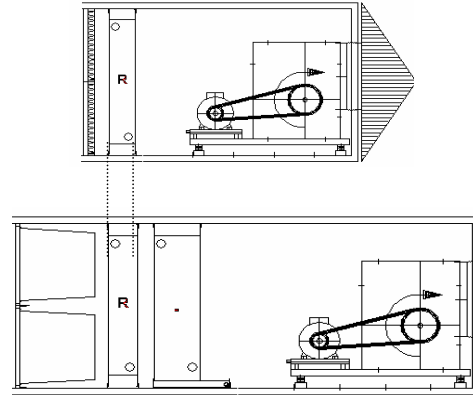

Recovery with RAC or HPR

# Energy Recovering System

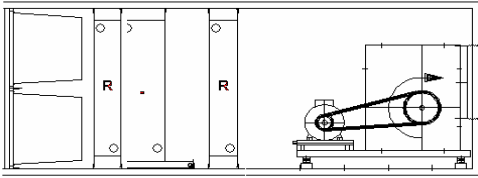

**Pre-Cool And Re-Heat with RAC or Pre-Cool and Re-Heat HPHS**

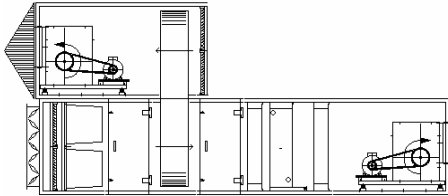

**Recovery with HWE (or HPE, HPR, RAC) plus Pre-Cool & Re-Heat with HPHS (or RAC)**

## PLATE RECOUPERATORS

### Description

#### Operation

The design provides for two airflows to pass crossways between the heat exchanger plates. The colder air when passing through the unit absorbs heat contained in the outgoing airflow. The two airflows are completely isolated by the sealed construction of the heat exchanger, which is designed for sensible heat transfer only. Neither dust nor odors are transmitted.

#### Construction

A group of aluminum plates are located diagonally in the recuperator casing which is formed of galvanized sheets riveted together. Silicone seal assures complete air tightness. The lower part of the casing forms a watertight pan to recover possible condensate.

#### Models

Three are offered of which two are of different efficiency due to different plate dimensions:

- ES: Standard Efficiency
- EH: High Efficiency
- EP: With an air bypass (BP)

### Recommendations

#### Limitations

The heat recovery units with aluminum plates can be used for:

- temperatures up to 150°C
- a maximum pressure differential of up to 1000 Pa

- a non corrosive atmosphere

#### Condensation

Depending on the operating conditions, the exhaust air might be cooled below its dewpoint with resultant condensation. A condensate discharge must therefore be provided on the exhaust airside.

#### Freeze-up

Direct intake of sub-zero air into the unit might cause freezing of the exchanger. The temperature at which freezing might occur depends on the temperature and the relative humidity of the exhaust air as well as on the proportion of outside air to exhaust air.

Freezing can be prevented by increasing the outside air temperature either with preheat or by recycling a part of the exhaust air or by bypassing a part of the outside air.

### Installation

The casing of the independent vertical heat recovery unit is connected to other components of the air handling unit. As with all air to air heat exchangers, plate recuperators give their best efficiency when they are situated at the suction side of the fan.

The supply and exhaust fans should be wired for simultaneous operation.

The condensate discharge tubing (PVC 32 mm) is connected at the bottom of the pan and passed through a lateral opening in the unit casing for connection to a U-trap and discharge.

Available for unit size of 4-module height and below with airflow not exceeding 15 000 m<sup>3</sup>/hr.

### RUN AROUND COILS

Two coils, one located in the exhaust air stream, the other in the supply air stream is interconnected with a pump in a closed circuit.

Heat passes from the hot supply air to the cold water in the tubes of the heat pick-up coil. The pump then passes this warm water to the heat rejection coil where the heat passes into the cold exhaust air thus cooling the water and warming the air. Cold water returns to the heat pick-up coil and the cycle is repeated.

Selection of the coils is made from 39F computer selection software and based on the following data:

- air handling unit size
- supply air and exhaust air quantities, temperature and humidity
- glycol concentration (if used)

# Energy Recovering System

## Advantages

- two completely separate airflow
- flexible duct arrangement
- simple installation
- great reliability
- low initial cost
- simple maintenance

## HEAT WHEEL

ASHRAE Standard 62-1989 that recommended level of outside air brought into buildings has been increased. This imposes much higher latent and sensible loads on cooling and heating equipment. Heat wheel is designed to recover total energy (sensible and latent) to meet the requirements of indoor Air Quality (IAQ), humidity control and to save energy.

The wheel made of aluminum heat storing matrix and with galvanized casing. The wheel is positioned in 39F Air Handling Unit so that it is divided into two half moon sections. Stale air from

the conditioned space is exhausted through one half while outdoor air is drawn through the other half in the counter flow pattern. At the same time wheel is rotated slowly.

Sensible heat is transferred as the metallic substrate picks up and stores heat from the warmer air stream and gives it up to the cooler section.

Latent heat is transferred as the synthesized metallic substrate condenses moisture from the air stream that has the higher humidity ratio through adsorption (with a simultaneous release of heat) and releases of moisture through evaporation (and heat pick-up) into the air stream that has a lower humidity ratio.

Selection detail is made from 39F computer selection software. Further inquiries please contact *Carrier* office.

## Energy Recovery Efficiency

Effectiveness for recovery equipment (latent, sensible and total) can be determined with following relations.

$$\varepsilon = \frac{\dot{m}_e}{\dot{m}_{min}} \frac{X_4 - X_3}{X_1 - X_3} \quad \varepsilon = \frac{\dot{m}_s}{\dot{m}_{min}} \frac{X_1 - X_2}{X_1 - X_3}$$

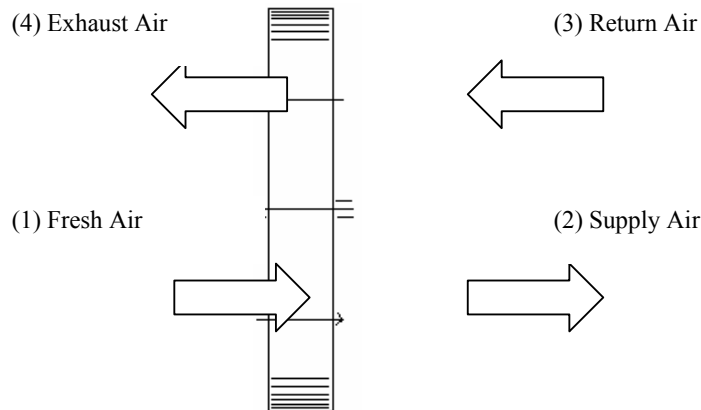

### Where:

- $\varepsilon$  = sensible, latent, or total heat effectiveness;
- $X$  = dry bulb temperature for sensible effectiveness, humidity ratio for latent effectiveness, total enthalpy for total effectiveness;
- $\dot{m}_e$  = mass flow rate of the exhaust, mass of dry air per unit time;
- $\dot{m}_s$  = mass flow rate of the supply, mass of dry air per unit time;
- $\dot{m}_{min}$  = minimum value of either mass flow rate;

# Energy Recovering System

Example From Flex Air :

Air side data			
	Fresh air	Exhaust air	
Airflow	15000	15000	m3/h
Air on dry bulb	46	25	°C
Relative humidity	30	50.0	%

<b><u>WHEEL HEAT EXCHANGER (EXHAUST AIR SIDE)</u></b>		Length = 2 module(s) Air pressure drop = 123 Pa
<u>Configuration</u>	<u>Performance</u>	
Type : Hygroscopic	Air ON Condition : 25.0° C / 50 % Airflow : 15000 m3/h Face Velocity : 3.47 m/s	
<b><u>WHEEL HEAT EXCHANGER (FRESH AIR SIDE)</u></b>		Length = 2 module(s) Air pressure drop = 123 Pa
<u>Configuration</u>	<u>Performance</u>	Total Capacity : 157 kW Efficiency : 73.1 %
Type : Hygroscopic	Air ON Condition : 46.0° C / 30 % Air OFF Condition : 30.7° C / 47 % Airflow : 15000 m3/h Face Velocity : 3.47 m/s	

Sensible efficiency at Fresh Air HWE side =  $(15000/15000) \times (46 - 30.65) / (46 - 25) = 73.1\%$

Supply temperature =  $(15000/15000) \times (0.731) (25 - 46) + 46 = 30.7 \text{ C DB}$

Generally, heat wheel performed the highest efficiency among the list of energy recovery equipment, ranged from 65% up to 85% depend to face velocity and fin martial.

**Energy Recovery Equipments  
Efficiency, % Vs Face Velocity, m/s**

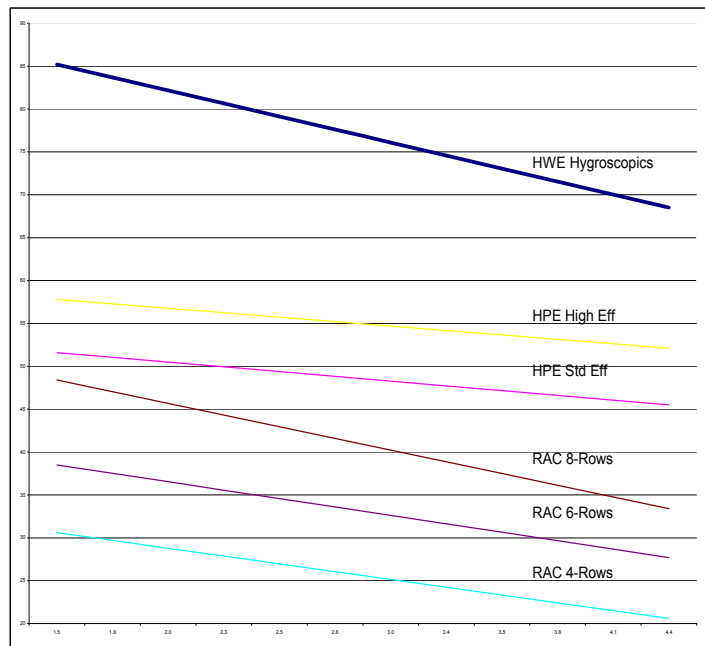

# Humidifiers

## GENERAL

Air humidification can be obtained by:

- adiabatic process (constant heat)
- isothermal process (constant temperature)

### Adiabatic Humidification (with water spray)

At constant enthalpy part of the sensible heat content of the air is converted into latent heat of evaporation. The efficiency of that process is defined by:

$$E\% = \frac{Xl - Xe}{Xs - Xe} \times 100$$

$Xl$  = quantity of water vapor in the air leaving the humidifier (g/kg)

$Xe$  = quantity of water vapor in the air entering the humidifier (g/kg)

$Xs$  = quantity of water vapor at saturation in the air entering the humidifier (g/kg)

### Isothermal Humidification (steam injection)

At constant temperature the amount of water in the air is increased and with it the enthalpy of the air.

## DESCRIPTION

The adiabatic or spray humidifier used with the 39F units consists of:

- Painted and bolted galvanized sheet metal panels (welding eliminated) and internally coated for water tightness.
- Water sump with level control and furnished with the following openings:
  - drain
  - overflow
  - water supply with float valve
  - suction connection with screen
- One or two rows of galvanized stand pipes with atomizing plastic spray nozzles providing a fine water mist for maximum efficiency (spray nozzles easily removed for maintenance)
- Vertical galvanized steel eliminator plates specially formed, and installed upstream and downstream to provide droplet elimination
- Porthole for assembly inspection (not furnished on sizes 220, 230 and 240)
- Inspection – maintenance door
- Recirculating centrifugal pump, field mounted by others

Note: units are supplied single skin, un-lagged.

Two models of humidifiers are available:

1. **Short humidifier** (medium efficiency)  
With one row of spray nozzles directed against the airflow. Maximum efficiency: 79% at 2.2 m/s coil face velocity. Overall length: 4 modules = 1310 mm.

2. **Long humidifier** (high efficiency)

Two rows of spray nozzles directed against the airflow. Maximum efficiency: 84% at 2.2 m/s coil face velocity. Overall length: 6 modules = 1940 mm.

## RECOMMENDATIONS

The following condition must be met:

- electrical interlock between pump and fan motor
- supply of filtered and treated water (pH = 7)
- continuous bleed-off to prevent salt accumulation in sump
- a drain U-trap twice the height of the fan static pressure
- adequate protection against freezing

## INSTALLATION

The humidifier forms an independent section to be connected to the other unit sections by using the accessories fixings supplied with the unit for this purpose.

Since the sump is located at the bottom of the humidifier and below the airflow, support legs for the other sections of the air handling units have to be provided to maintain uniform level. These support legs are factory supplied as optional accessories.

The recirculating pump must be field connected and located at the same height as the sump. A free space of 600 mm for this installation is required.

## SELECTION

*Example:*

Unit 39FD 570, entering air 7500 l/s at 2.7 m/s (standard coil face velocity), entering air at 25°C and  $Xe = 3$  g/kg water vapor.

- Required; leaving air  $Xl = 7.5$  g/kg
- From the psychrometric chart read ; saturation of entering air  $Xs = 8.5$  g/kg
- Efficiency  $E\% = \frac{7.5 - 3}{8.5 - 3} \times 100 = 82\%$
- From humidifier efficiency curve at 2.7 m/s  
For one spray tree:  $E = 74\%$   
For two spray trees:  $E = 80\%$
- Two spray trees humidifier satisfies the requirements

The actual leaving air conditioners are

$$Xl = 0.80 \times (8.5 - 3.0) + 3 = 7.4 \text{ g/kg}$$

Leaving air temperature: 14.5°C with 75% R.H.

# Humidifiers

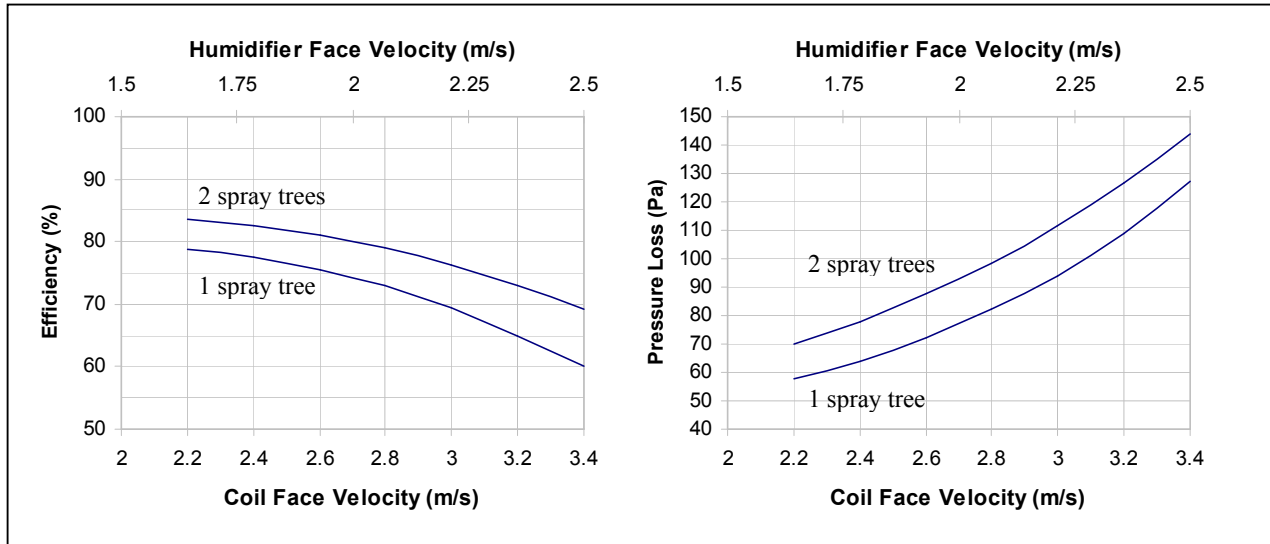

Efficiencies and airside pressure losses through humidifiers

## Weight of humidifiers and water charges

Unit size 39F	1 spray tree		2 spray tree	
	Weight (kg)	Water charge (kg)	Weight (kg)	Water charge (kg)
220	170	140	240	210
230	205	215	295	320
240	220	290	310	430
330	230	215	330	320
340	260	290	375	430
350	315	370	460	550
360	365	430	535	720
370	410	520	605	770
440	335	290	485	430
450	375	370	550	550
460	430	430	635	720
470	490	520	720	770
480	545	600	810	885
550	425	370	640	550
560	490	430	730	720
570	560	520	810	770
580	620	600	930	885
660	560	430	835	720
670	635	520	950	770
680	690	600	1065	885
770	705	520	1065	770
780	790	600	1200	885
7100	955	750	1450	1110

# Humidifiers

## Dimensional drawing

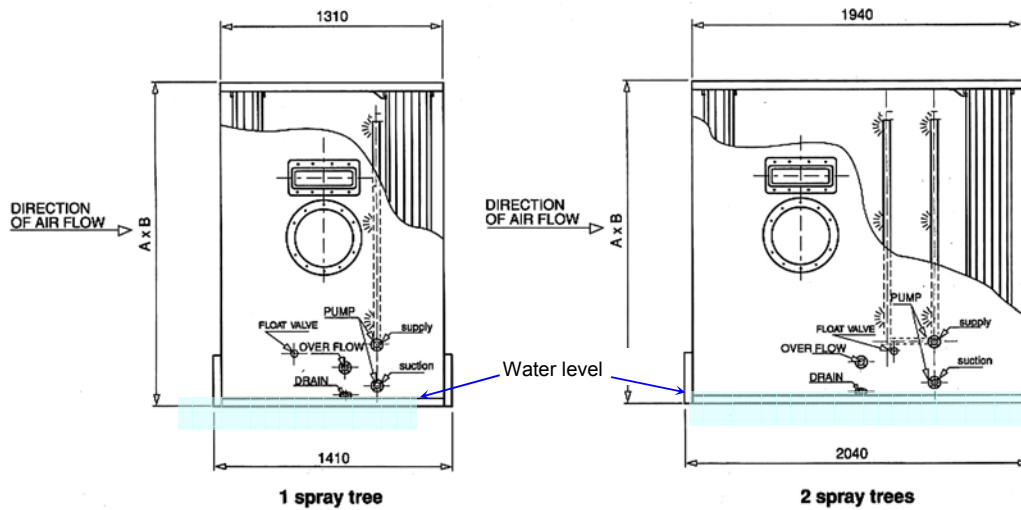

Connections : Drain G 1 1/2" FPT  
 Overflow G 1 1/2" MPT  
 Float valve G 1/2" MPT

## Physical data

Unit size 39F	A (mm)	B (mm)	Max air volume l/s	1 tree counter flow				2 trees counter flow			
				Recircul ated water volume l/s	Pump kW	Suction dia	Supply dia	Recirculated water volume l/s	Pump kW	Suction dia	Supply dia
220	995	680	650	0.24	0.55	1"	1"	0.32	0.55	1"	1"
230		995	1150	0.42	0.55	1"	1"	0.72	0.55	1"	1"
240		1310	1650	0.58	0.55	1"	1"	1.01	0.75	1" 1/4	1" 1/4
330	1310	995	1900	0.68	0.55	1"	1"	1.18	0.75	1" 1/4	1" 1/4
340		1310	2650	0.94	0.75	1" 1/4	1" 1/4	1.65	0.75	1" 1/4	1" 1/4
350		1625	3550	1.32	0.75	1" 1/4	1" 1/4	2.40	1.5	2"	2"
360		1940	4350	1.51	0.75	1" 1/4	1" 1/4	2.67	1.5	2"	2"
370		2255	5150	1.83	1.5	2"	2"	3.19	1.5	2"	2"
440		1310	3700	1.31	0.75	1" 1/4	1" 1/4	2.28	1.5	2"	2"
450	1625	1625	4950	0.75	0.75	1" 1/4	1" 1/4	3.06	1.5	2"	2"
460		1940	6000	1.13	1.5	2"	2"	3.72	4	2"	2"
470		2255	7150	2.54	1.5	2"	2"	4.44	4	2"	2"
480		2570	8300	2.94	1.5	2"	2"	5.15	4	2"	2"
550		1625	6600	2.33	1.5	2"	2"	4.07	4	2"	2"
560	1940	1940	8000	2.83	1.5	2"	2"	4.96	4	2"	2"
570		2255	9550	3.39	4	2"	2"	5.22	4	2"	2"
580		2570	11083	3.92	4	2"	2"	6.88	3	2" 1/2	2"
660		1940	9650	3.43	4	2"	2"	6.00	4	2"	2"
670	2255	2255	11550	4.08	4	2"	2"	7.14	3	2" 1/2	2"
680		2570	13400	4.72	4	2"	2"	8.31	3	2" 1/2	2"
770		2255	13550	4.79	4	2"	2"	8.38	3	2" 1/2	2"
780	2570	2570	15700	5.50	4	2"	2"	9.72	3	2" 1/2	2"
7100		3200	20100	4.95	3	2" 1/2	2"	12.60	3	2" 1/2	2"

Note: Water pump & external piping are not factory supplied.

# Sound Attenuators

**GENERAL**

Where a significant reduction to fan noise is required attenuators can be provided.

**DESCRIPTION**

Sound absorption is achieved by installing mineral wool splitters (non-combustible class MO fire code), fixed in galvanized steel frames and mounted parallel to the airflow.

Various splitter lengths are available to provide a range of attenuator performances.

The sides exposed to the air stream are covered with a glass fiber scrim to avoid erosion to the mineral wool by the air stream.

The standard thickness of the splitters is 200 mm.

**RECOMMENDATIONS**

Following limits are to be observed

- Maximum air velocity between panels: 20 m/s
- Maximum temperature: 100°C

**INSTALLATION**

The splitters are installed within the 39F unit and form an integral part of it. They can be located in the discharge or inlet sides of supply or return fan.

**DIMENSIONS**

The height is determined by the height of the air handling unit.

The amount of sound absorption depends on the splitter length.

The length of the splitter casing takes into account the space required for uniform airflow after leaving the attenuator splitters.

**MANUAL PRESELECTION**

Deduct silencer sound attenuation figures (table below) from fan sound power spectrum to arrive at sound level leaving the attenuator.

Exact calculations are made by computer program.

Splitter length	63Hz	125Hz	250Hz	500Hz	1kHz	2kHz	4kHz	8kHz
<b>3 modules</b>	4	7	12	20	25	22	19	11
<b>4 modules</b>	5	9	17	28	35	30	26	16
<b>5 modules</b>	7	11	21	35	44	39	33	20
<b>6 modules</b>	9	14	26	42	50	46	40	24

*Deduct values (dB) from fan sound power spectrum to arrive at sound level leaving attenuator*

# Application Guide

Parts of the considerations while selecting an AHU are the space area available for installation and the unit application. This limitation will determine the unit size and unit configuration.

## SERVICE CLEARANCE

Allow adequate clearance for servicing and maintenance access (filter and coil removal, motor and fan shaft servicing). Avoid any piping, conduit or ductwork that might obstruct the service door access and space. For sufficient clearance space guideline please refer to the Installation Operating Manual.

## CONDENSATE DRAIN

Install a trapped condensate drain line at appropriate location to avoid back flow of condensate water and to ensure proper drainage. Guide line of U-trap installation as per the operating manual.

## UNIT CONFIGURATIONS

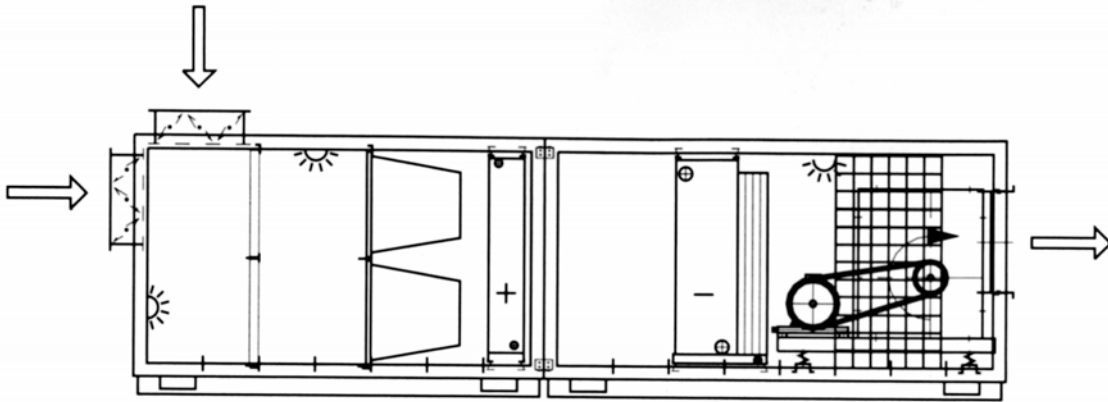

**Horizontal Draw Through Unit**

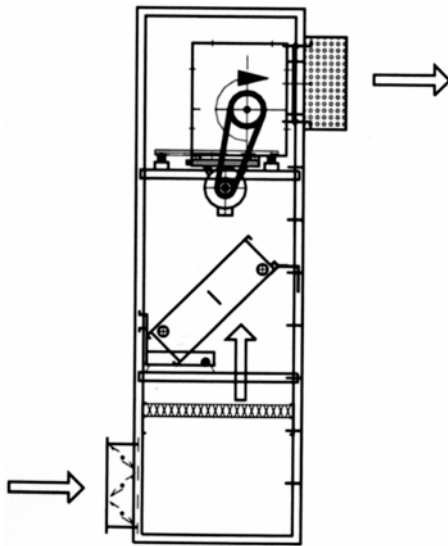

**Vertical Draw Through I-unit**

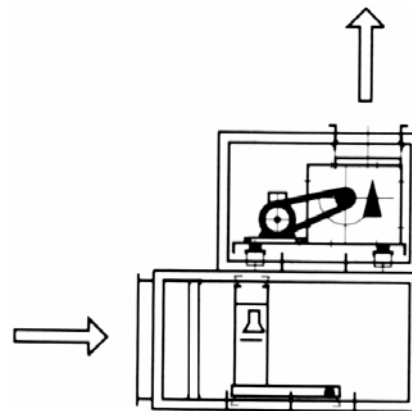

**Vertical Draw Through L-unit**

# Application Guide

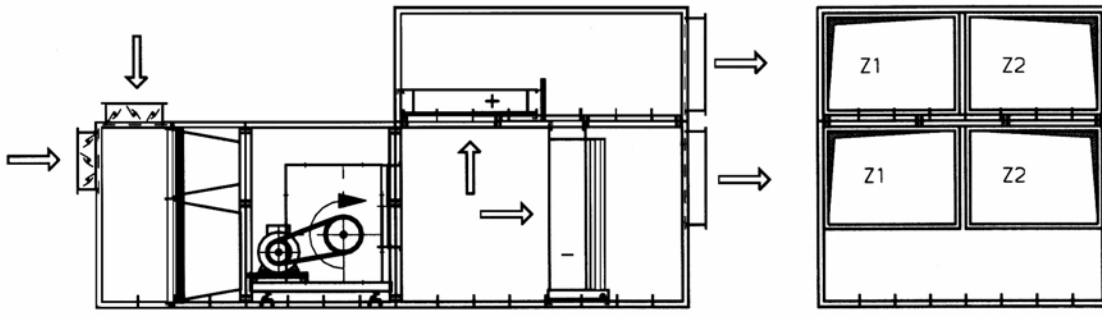

Multizone Unit

(Front view)

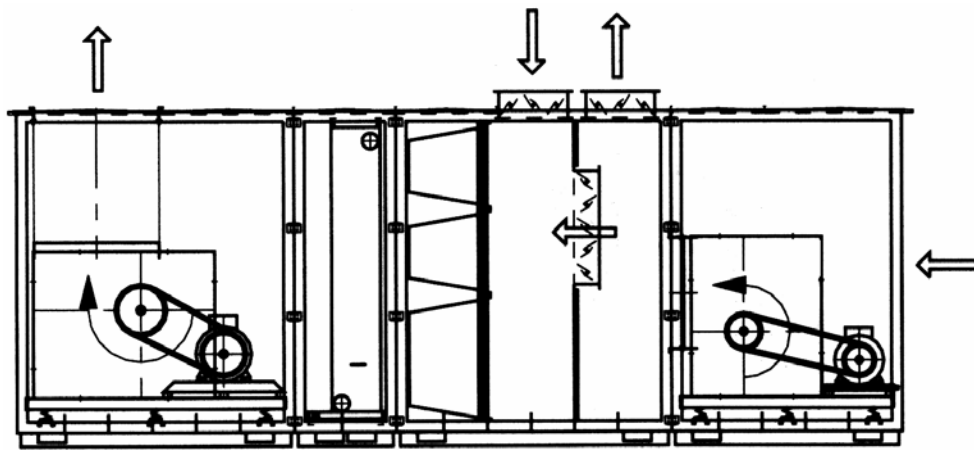

Unit with Return and Supply Fan

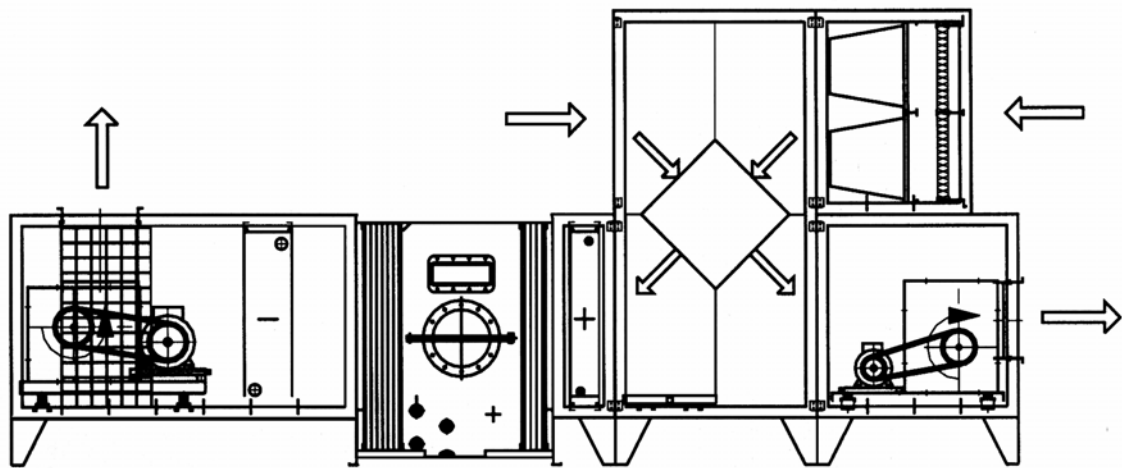

Unit with Air Washer and Plate Recouperator

# Application Guide

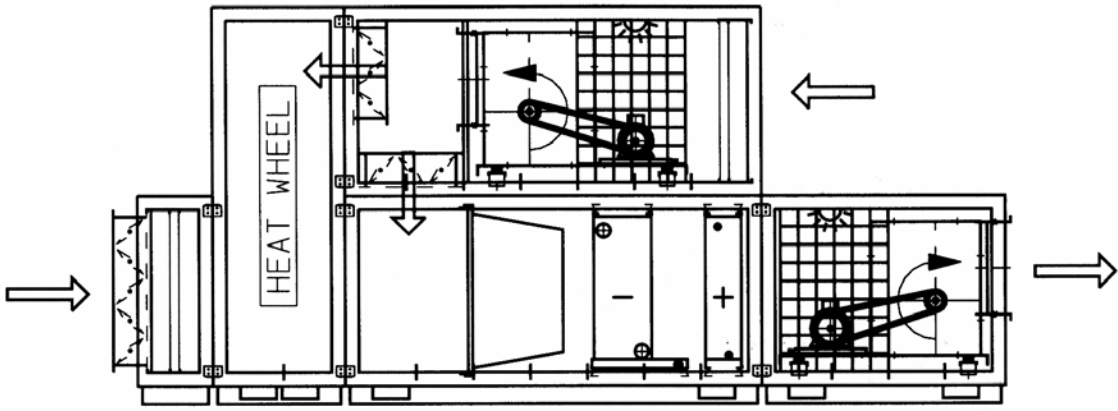

Unit with Heat Wheel

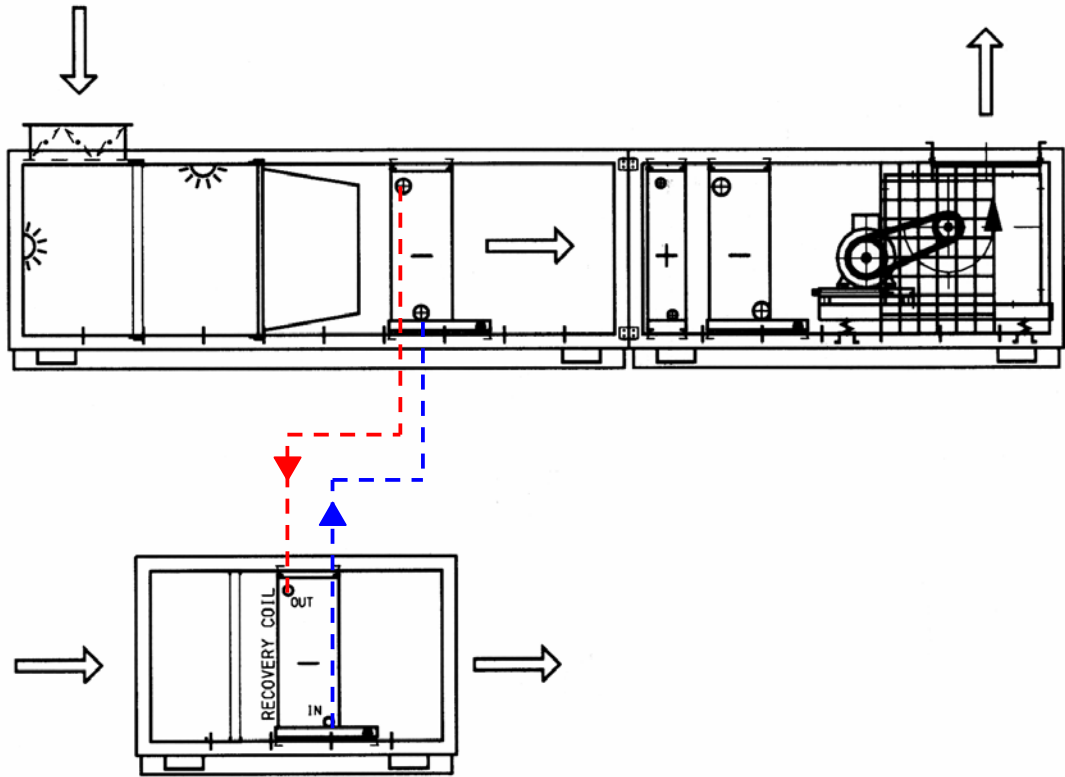

Unit with Recovery Coil

# Appendix

# Conversion Table

From	To		Multiply by
<b>LENGTH</b>			
inches	millimeters	mm	25.4
feet	meters	m	0.3048
yards	meters	m	0.9144
miles	kilometers	km	1.609
<b>AREA</b>			
Square inches	square millimeters	mm <sup>2</sup>	654.2
Square feet	square meters	m <sup>2</sup>	0.0929
Square yards	square meters	m <sup>2</sup>	0.8361
<b>VOLUME</b>			
Cubic feet	cubic meters	m <sup>3</sup>	0.0283
Cubic yards	cubic meters	m <sup>3</sup>	0.7646
Quarts	liters	l	0.9464
US Gallons	liters	l	3.7854
Cubic centimeters	milliliters	ml	1
<b>MASS</b>			
Pounds	kilograms	kg	0.4536
Metric ton (2000lb)	tons (1000kg)	t	0.907
US ton (2240lb)	tons (1000kg)	t	1.016
<b>TEMPERATURE</b>			
°F	°C	°C	(°F-32)÷1.8
°C	°F	°F	(°C x 1.8)+32
°C	Kelvin	K	°C + 273.15
<b>ENERGY</b>			
BTU	kilojoules	kJ	1.055
Kilowatt-hour	kilojoules	kJ	3600
<b>POWER</b>			
Horsepower	kilowatts	kW	0.746
<b>HEAT FLOW</b>			
BTU/hr	watts	W	0.2931
BTU/hr	kilocalories/hr	kcal/hr	0.2519
Tons (refrigeration)	kilowatts	kW	3.517
Tons (refrigeration)	kilocalories/hr	kcal/hr	3024
<b>HEAT TRANSFER COEFFICIENT</b>			
BTU/hr/ft <sup>2</sup> /°F	watts/m <sup>2</sup> /°C	W/m <sup>2</sup> /°C	5.678
kcal/hr/m <sup>2</sup> /°C	watts/m <sup>2</sup> /°C	W/m <sup>2</sup> /°C	1.163
<b>VOLUME FLOW</b>			
CFM	cubic meter/sec	m <sup>3</sup> /s	0.000472
CFM	liter/sec	l/s	0.472
CFM	cubic meter/hour	m <sup>3</sup> /hr	1.699
GPM (US)	liter/sec	l/s	0.0631
GPM (Imperial)	liter/sec	l/s	0.0757
m <sup>3</sup> /hr	liter/sec	l/s	0.2778
<b>VELOCITY</b>			
FPM	meter/sec	m/s	0.0051
<b>PRESSURE</b>			
in. of water (iwg)	kilopascal (kN/m <sup>2</sup> )	kPa	0.249
ft of water (H <sub>2</sub> O)	kilopascal	kPa	2.99
Pounds/sq.in (psi)	kilopascal	kPa	6.895
Pounds/sq.in (psi)	kilogram/sq.centimeter	kg/cm <sup>2</sup>	0.0703
ft of water (H <sub>2</sub> O)	bar	bar	0.03
Pounds/sq.in (psi)	bar	bar	0.0693



# PSYCHROMETRIC CHART

NORMAL TEMPERATURES  
Barometric Pressure 101.325 kPa  
SEA LEVEL

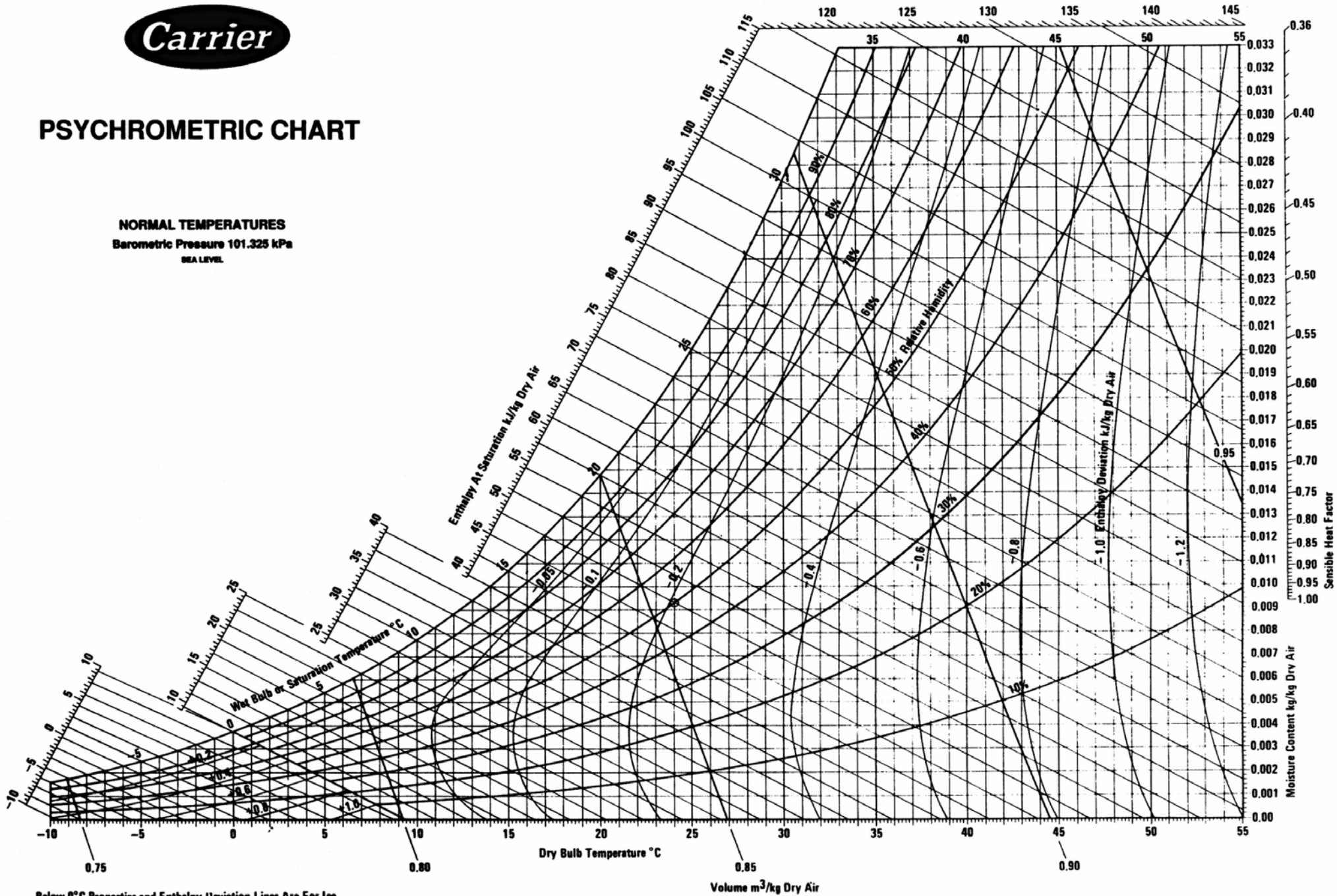

Below 0°C Properties and Enthalpy Deviation Lines Are For Ice

## Notes

# Notes



Turn to the Experts™

---

Manufacturer reserves the right to discontinue, or change at any time, specifications or designs without notice and without incurring obligations